

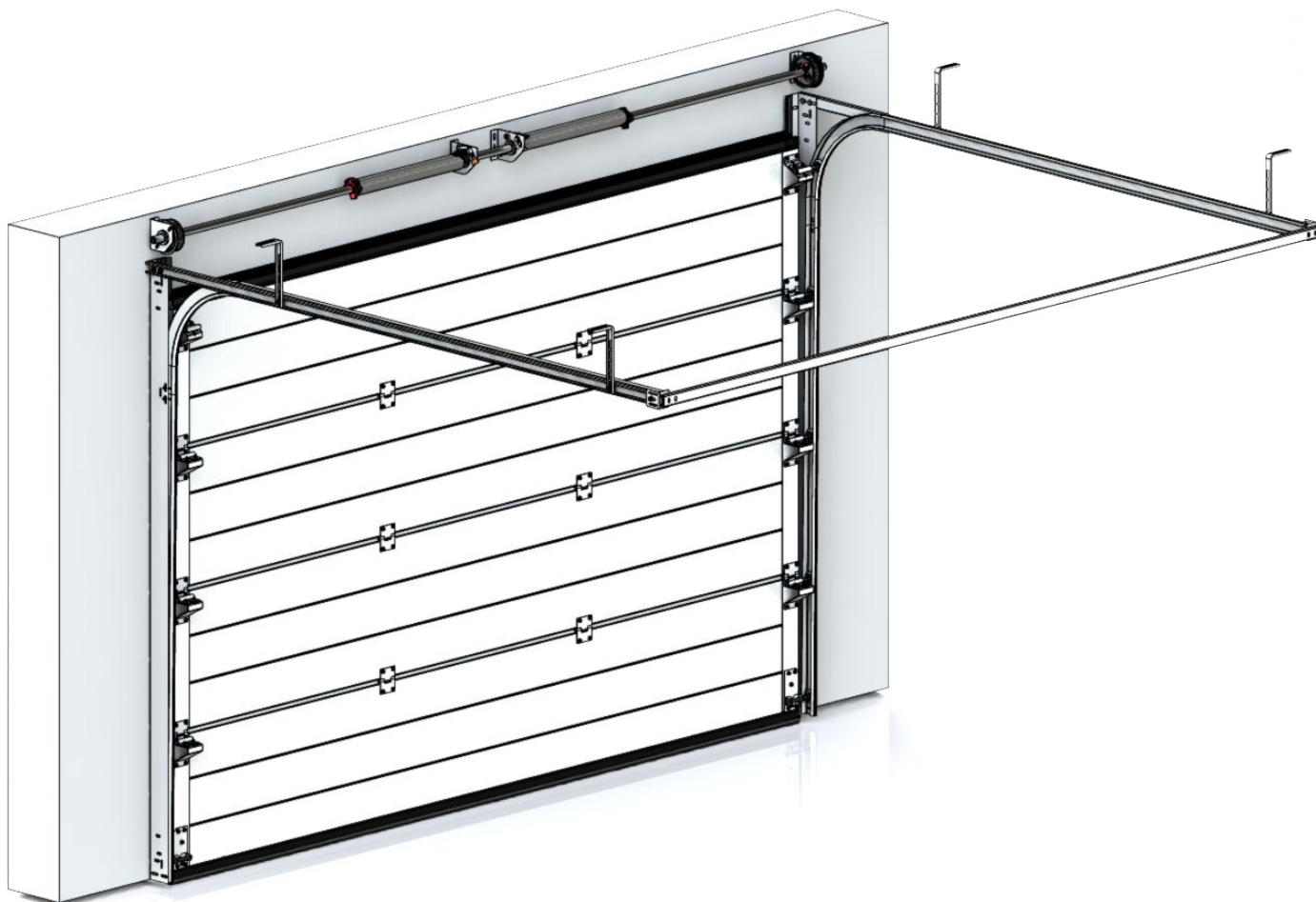

PASEDO [®]
Garage door components

FOR PROFESSIONAL ASSEMBLY

RF/RK 350



1. Guarantee conditions

The manual has been prepared to be used by qualified workers and cannot be used by people who are not entitled. Should any questions or doubts occur, you are requested to contact PASEDO company. The manual presents correct way of montage of garage door hardware only. In order to assembly a garage door with sandwich panel and other devices, the producer should follow manuals of the sandwich panel and other devices. The sandwich panel and other devices should be produced according to European Union rules.

2. Assembly conditions

Unprofessional assembly, any variations of the assembly that are not in accordance with this manual, will be made on the garage door Producer's responsibility. This also applies to any damages caused by improper use and not following the rules of this manual as well as improper service. The system presented in this manual should be used in residential buildings only and can be assembled and run by qualified workers only.

- The garage door can be assembled and put into operation by qualified workers only.
- Make sure that during working with electric devices the power is off.
- Security devices should never be switched off!
- Be careful in case of keen edges, use gloves.
- If visible damages of security device occur, stop further using of the door.
- While assembly/maintenance of the door it is recommended to always use gloves and protection shoes, and during drilling use the protection glasses.
- Make sure that works are carried out in a stable environment.
- Mark out the place of working with a tape so that the children and other people keep a distance.
- The maintenance to be carried out by a professional company or person only.
- Provide sufficient lighting.
- Use the suitable tools, especially for springs torsioning.

3. Control and service just after assembly

When assembly is finished worker should control if all elements are mounted in accordance with the manual, properly tightened as well as they should provide:

- lubrication of shaft bearings and rollers,
- lubrication of hinges,
- lubrication of steel cable,
- placement of Identification Card and required warning labels.

4. Passing the finished product to customer

Producer of door passes it to a user and shows him the way of working of the product, instructs him how to use the door and provide the following documents:

- manual of use and service,
- instructions what to do in case of incorrect working of door.

5. Garage door maintenance and overview

Door overview shall be signed in Door Service Book.

After 3 months since door assembly, assembling person (service person) makes:

- visual control of all elements,
- control of proper door operating and tightening the fasteners if needed.

After 6 months or after 700 cycles the user shall:

- remove impurities from door that have influence on correct working of door,
- lubricate the bearings and rollers,
- lubricate the hinges.

After 12 months since assembly repairer (assembling person) shall control and maintenance of proper door operating:

- roller (damages, material consumption, lubrication),
- control of steel cables consumption, especially connections with cable drums and bottom brackets and working places of cable pulleys if applied,
- control of cable pulleys consumption, if applied,
- spring break device control,
- control of horizontal track connection with ceiling,
- control of shaft brackets,
- control of seals (top, bottom and side) consumption and damages
- control of shaft coupler, if applied.

6. Garage door operator

All electric devices (including operators) that are a part of garage door shall fulfill requirements of European Union standards. Assembly of operator shall be made in accordance with operator's producer's manual. In case of lack of power supply or if there is no separate entrance into the garage, door shall be equipped with drive releaser.

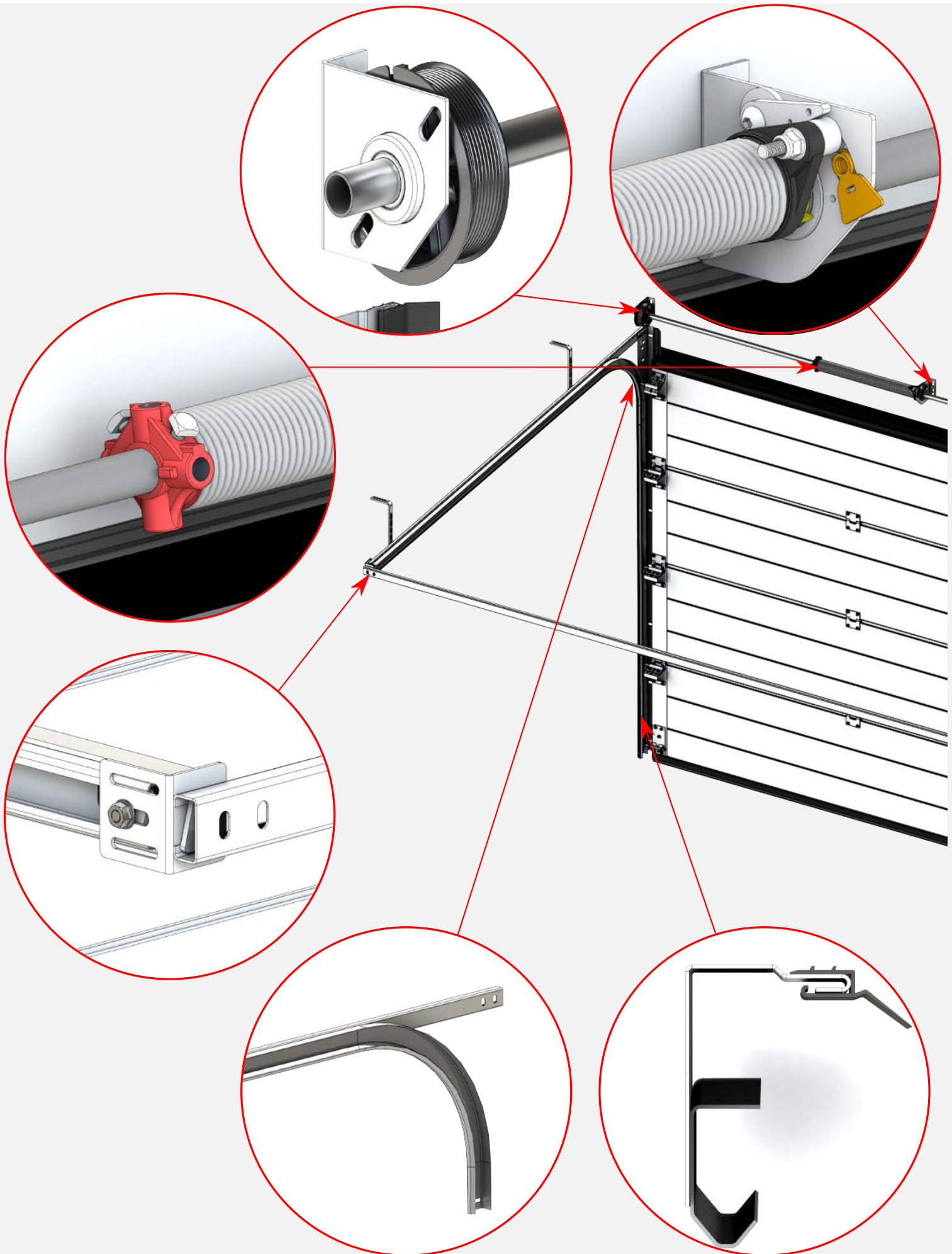

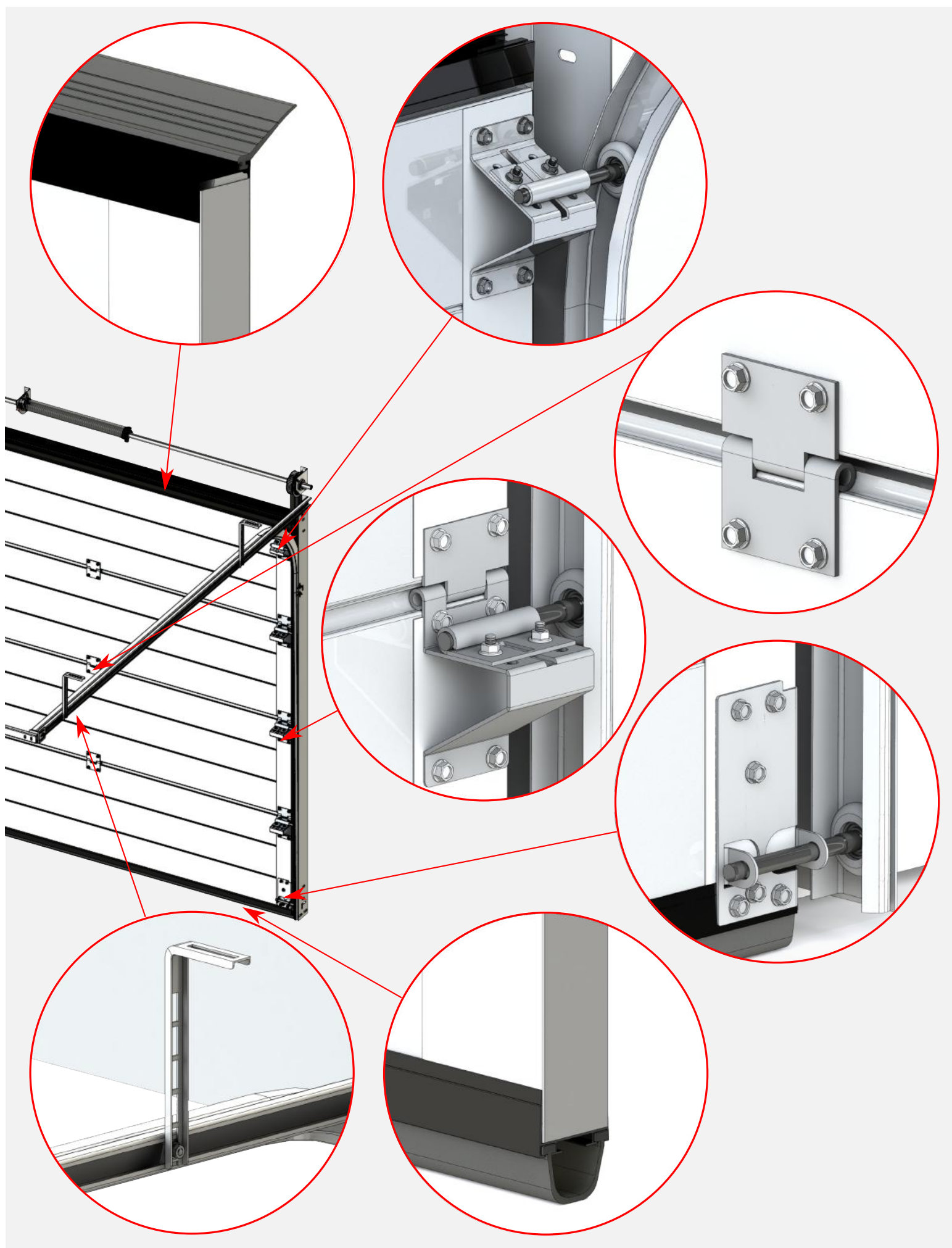

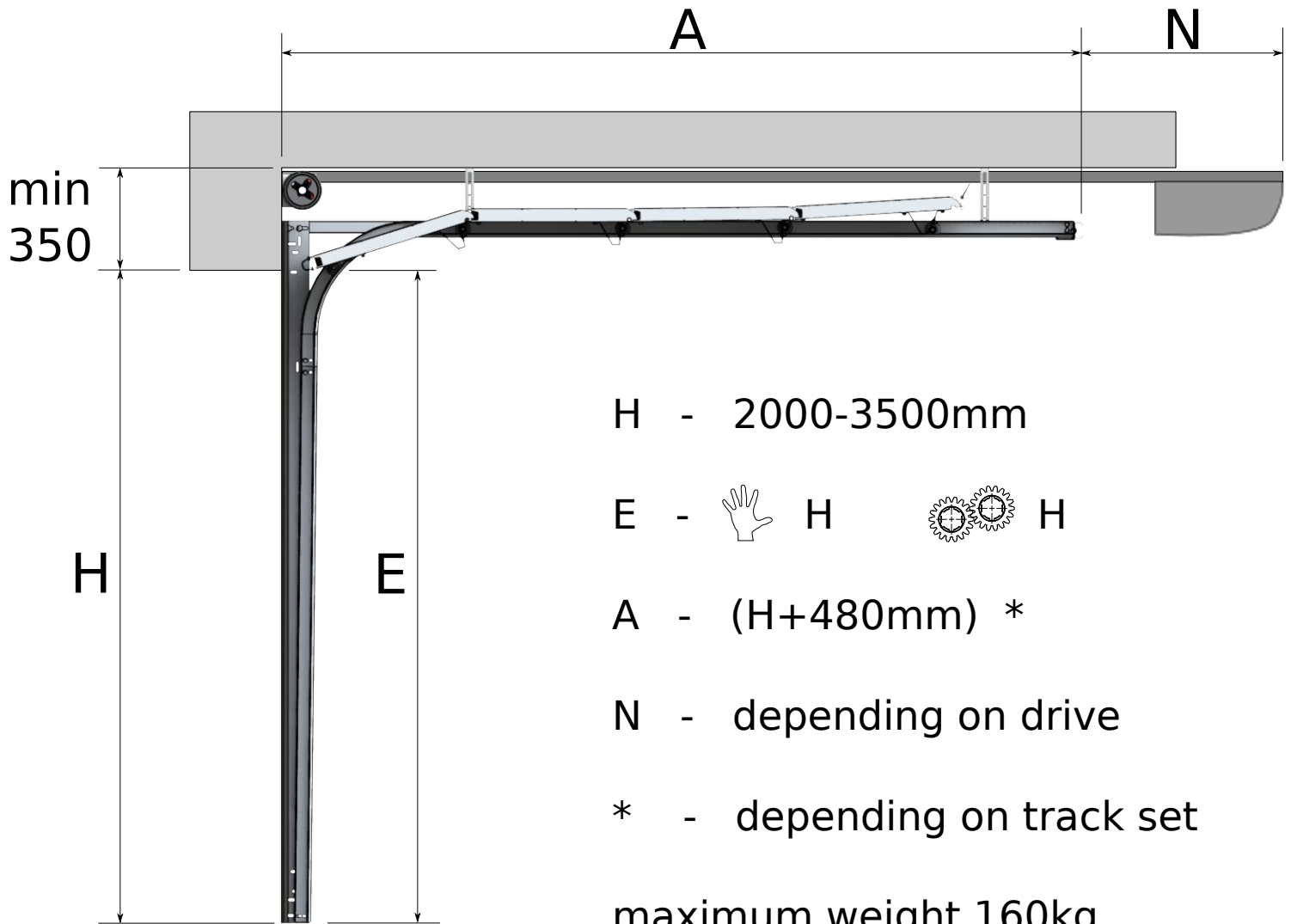



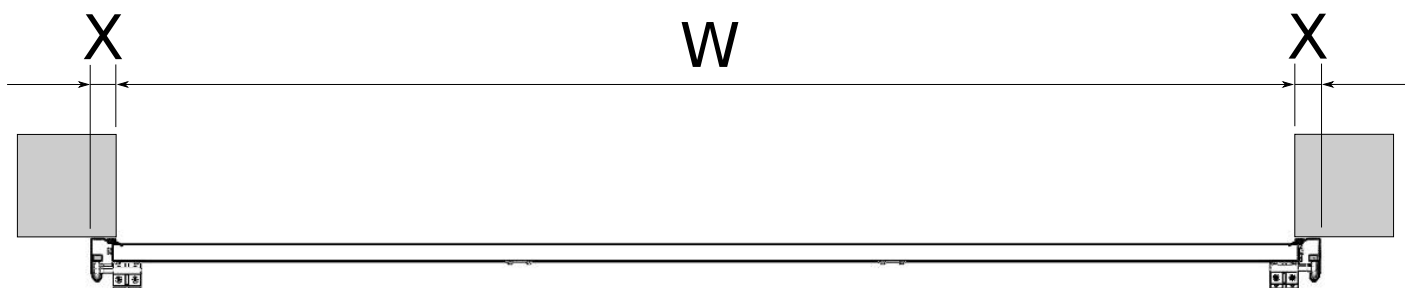

maximum weight 160kg

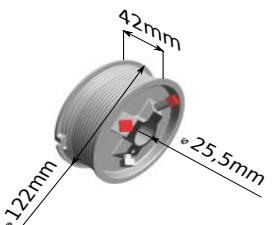
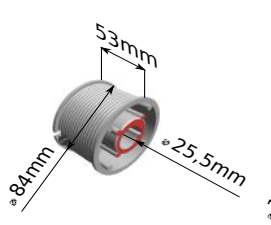
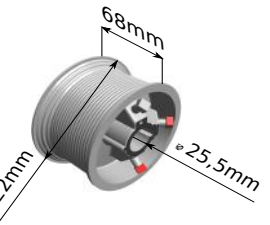

W - < 5000mm

X - 75mm

	4008 SL	4010 SL	4012 SL
			
no safety winding  bez zwojów bezpieczeństwa half safety winding	max H 2680mm	max H 3100mm	max H 4000mm
 połowa zwoju bezpieczeństwa two safety windings	max H 2500mm	max H 2980mm	max H 3830mm
 dwa zwoje bezpieczeństwa	max H 1960mm	max H 2600mm	max H 3300mm

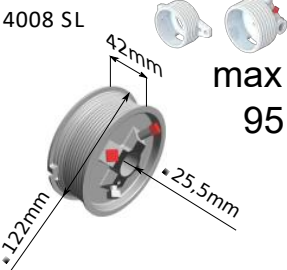
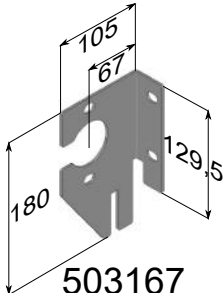
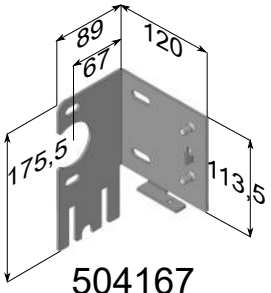
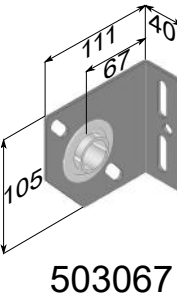
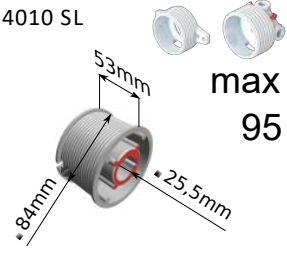
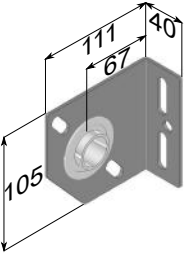
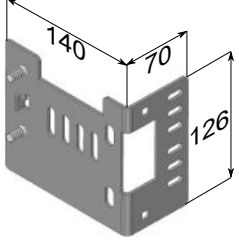
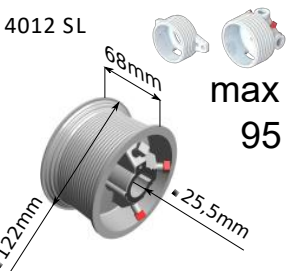
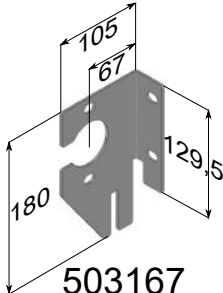
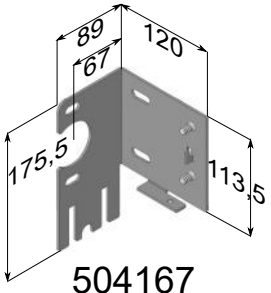
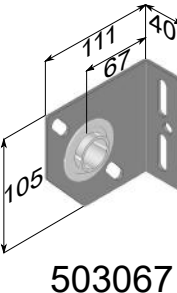
4008 SL  max 95	 503167	 504167	 503067
4010 SL  max 95	 503067	 533002	
4012 SL  max 95	 503167	 504167	 503067

1.0



34....



RF/RK350-....V R



RF/RK350-....V L

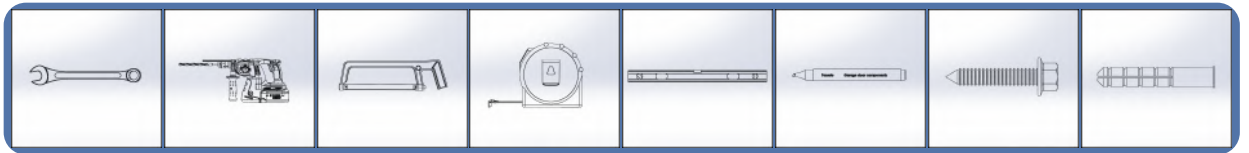

1.1

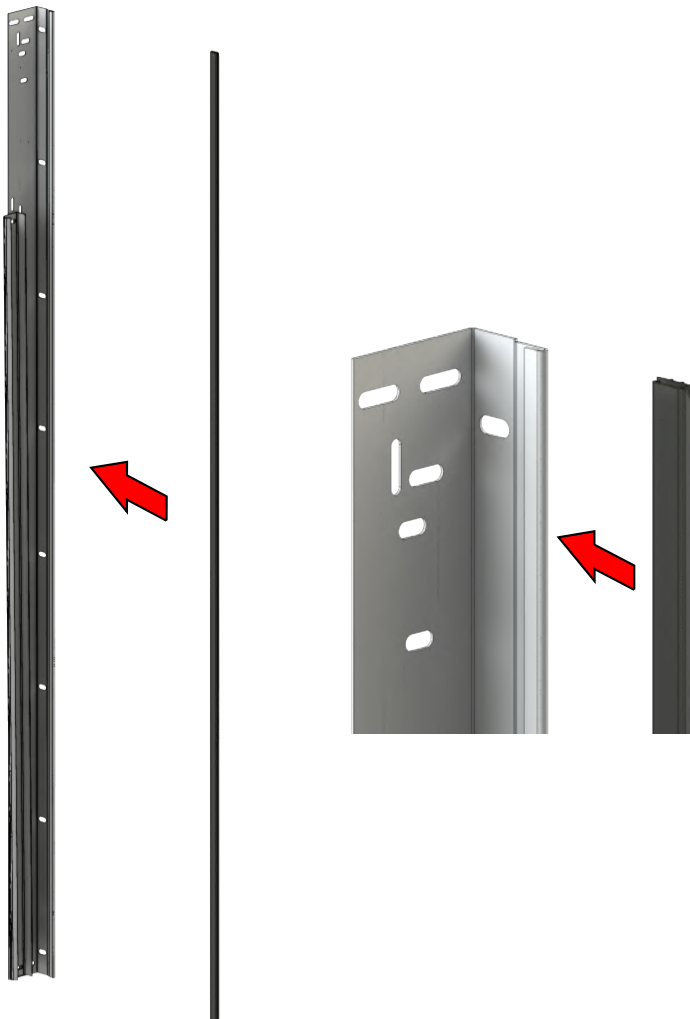

1.2



1.3

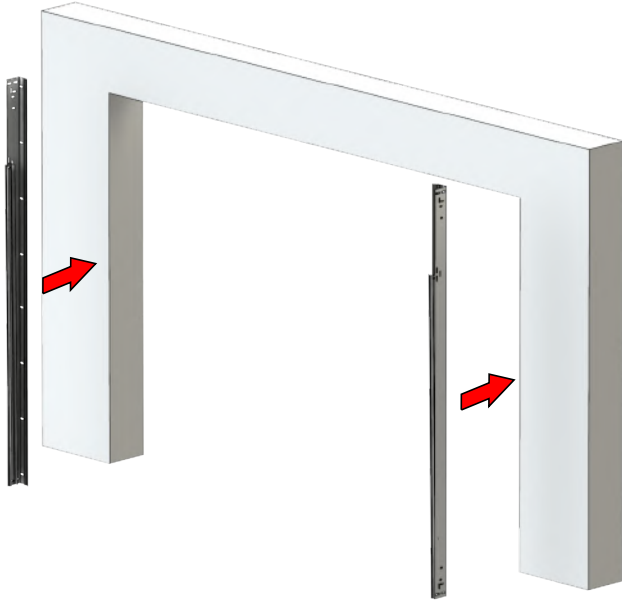

1.4

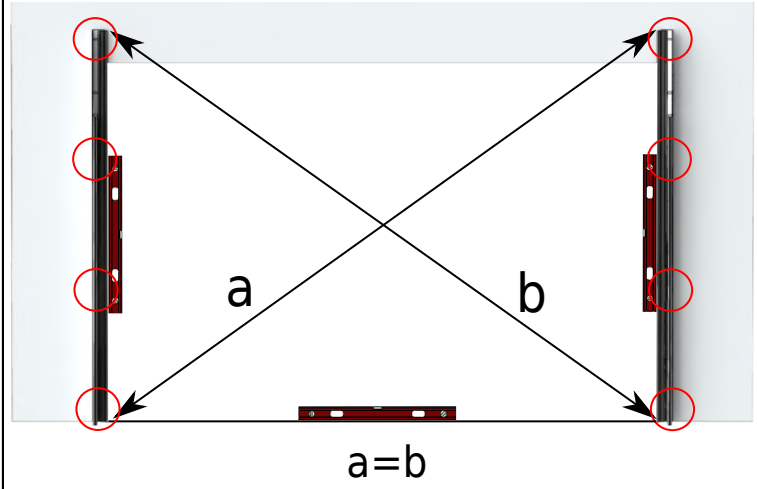

1.5



1.6

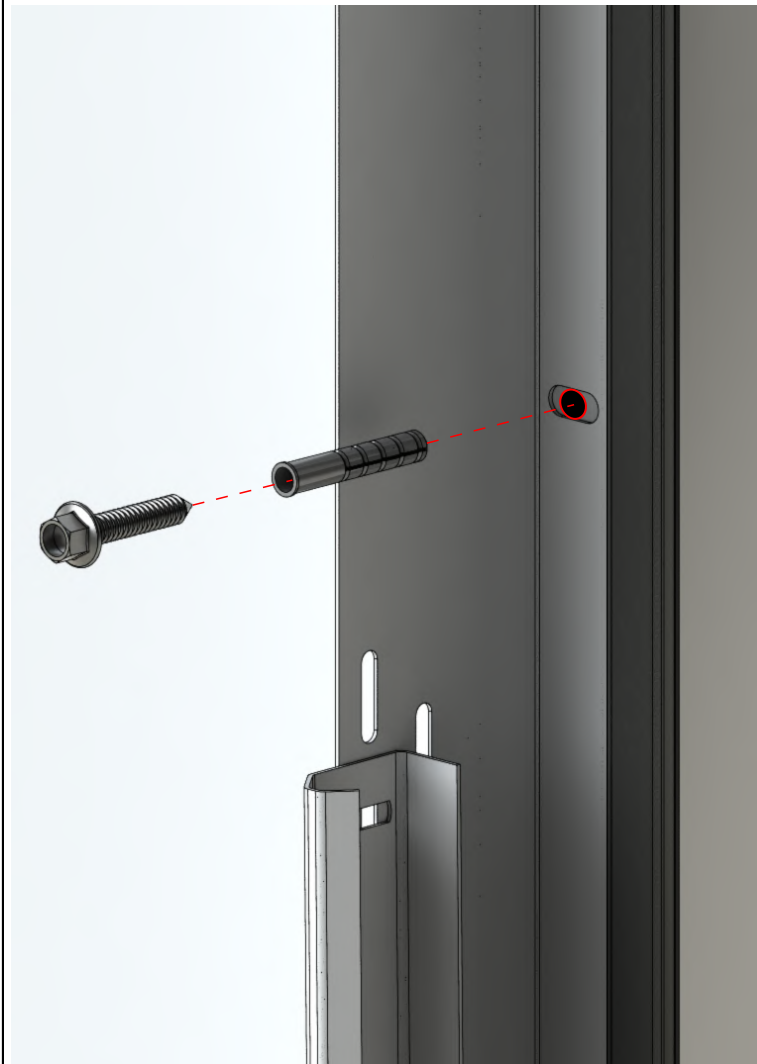

2.0

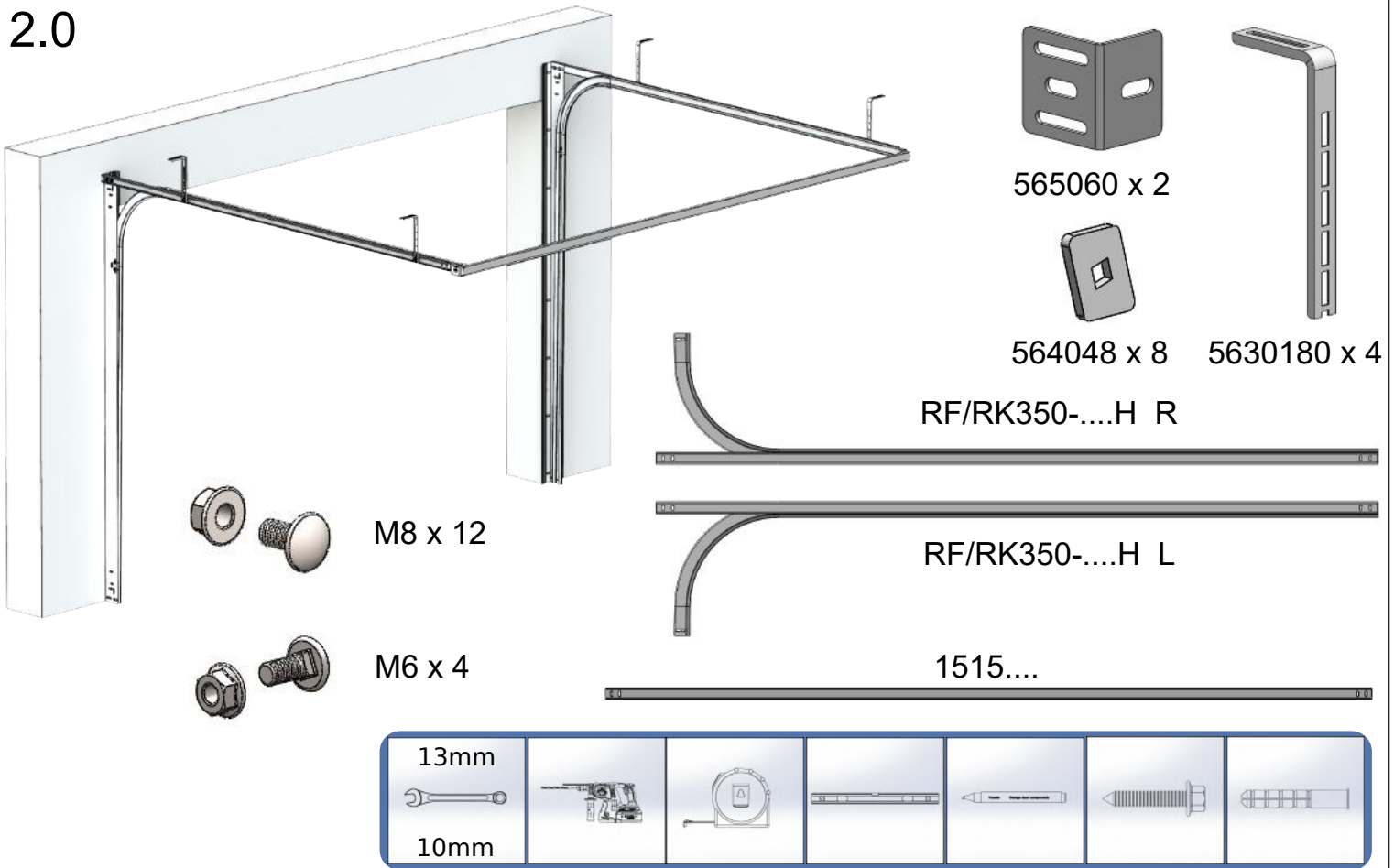

2.1

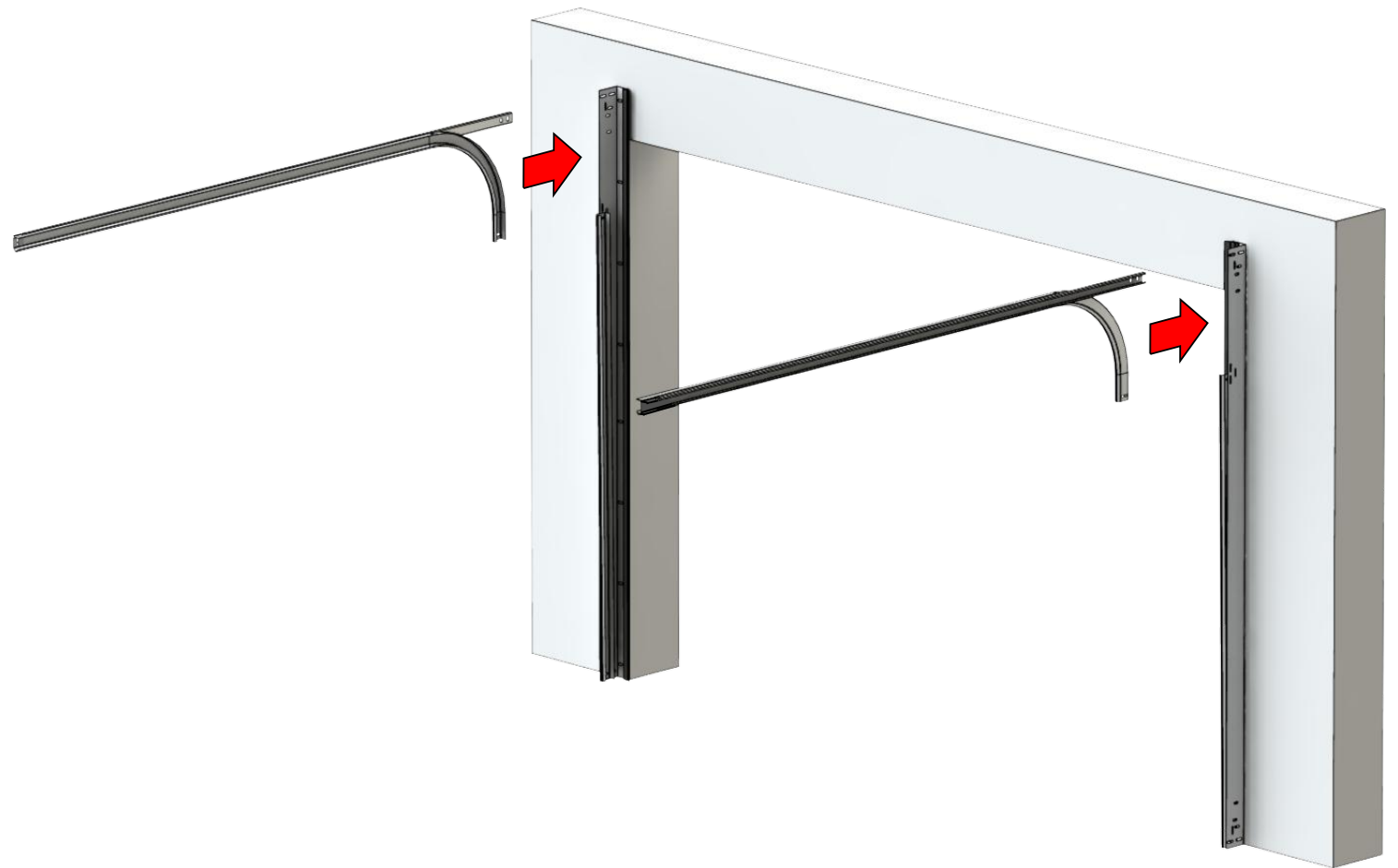

2.2

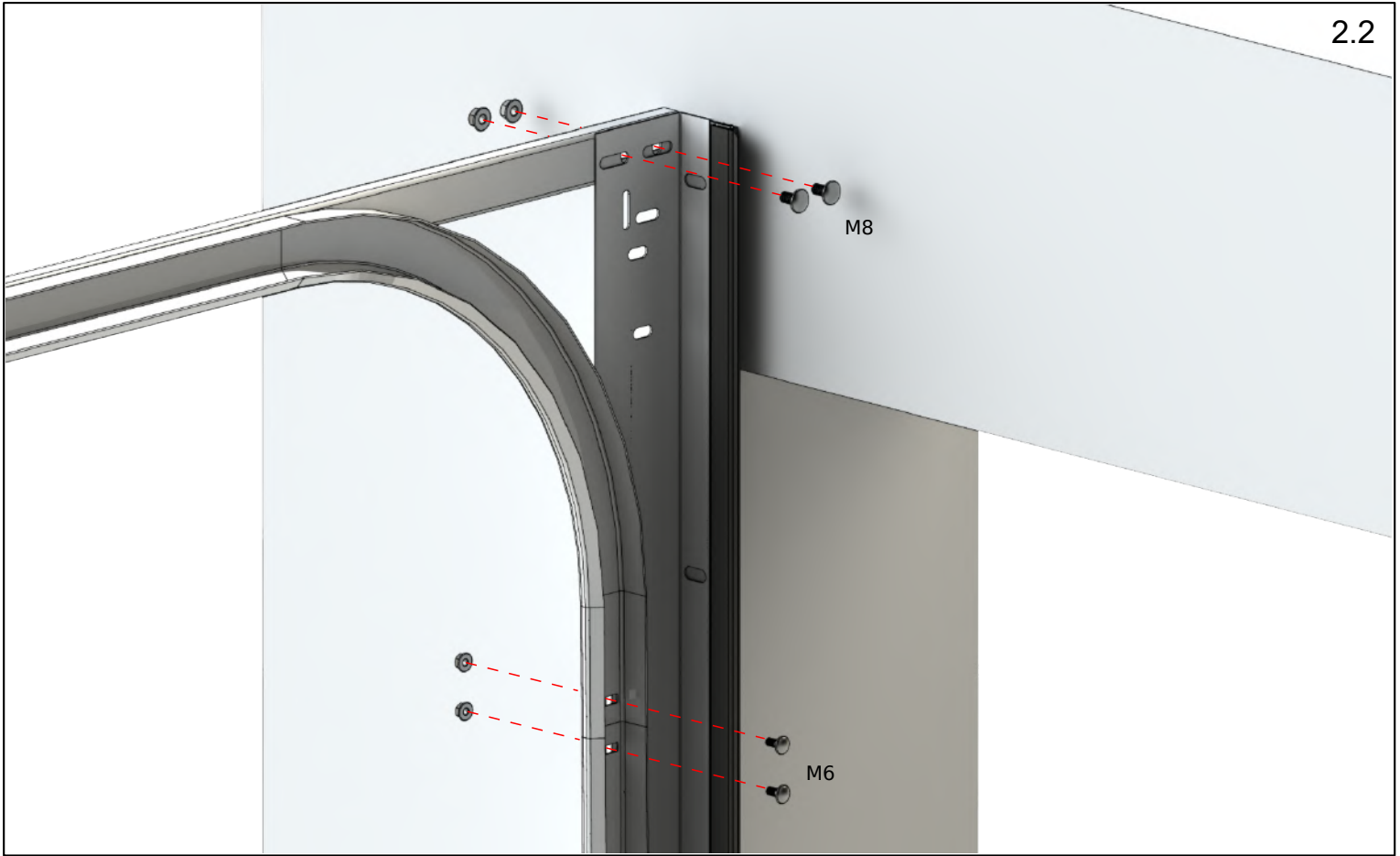

2.3

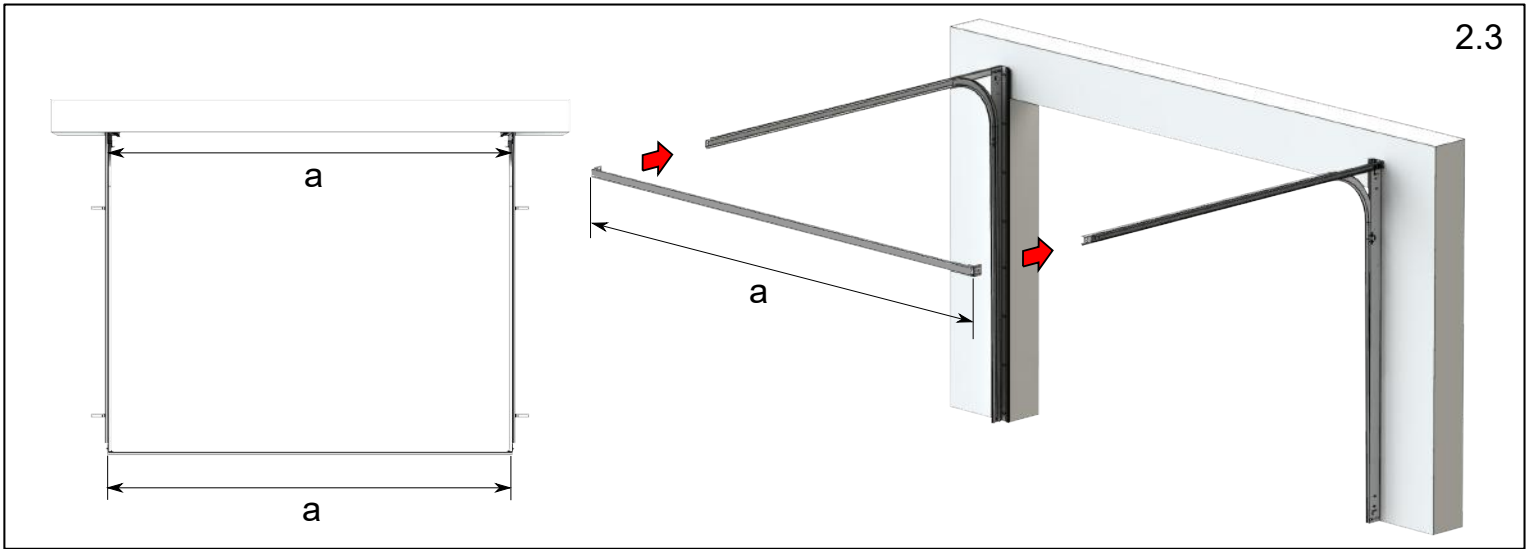

2.4

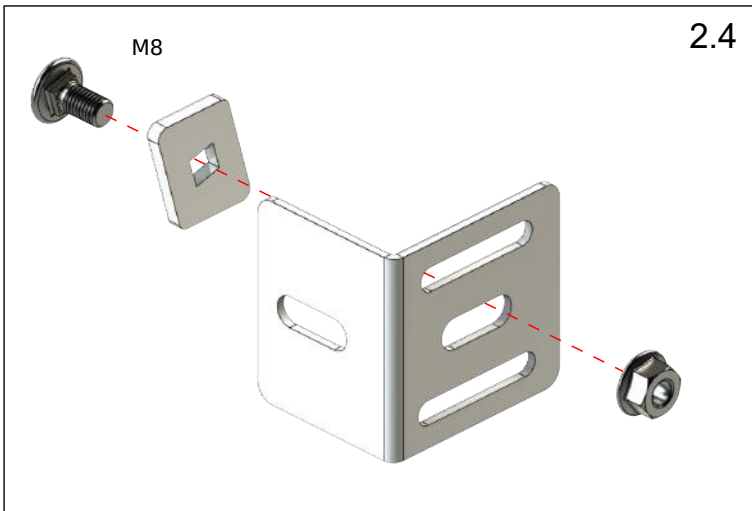

2.5

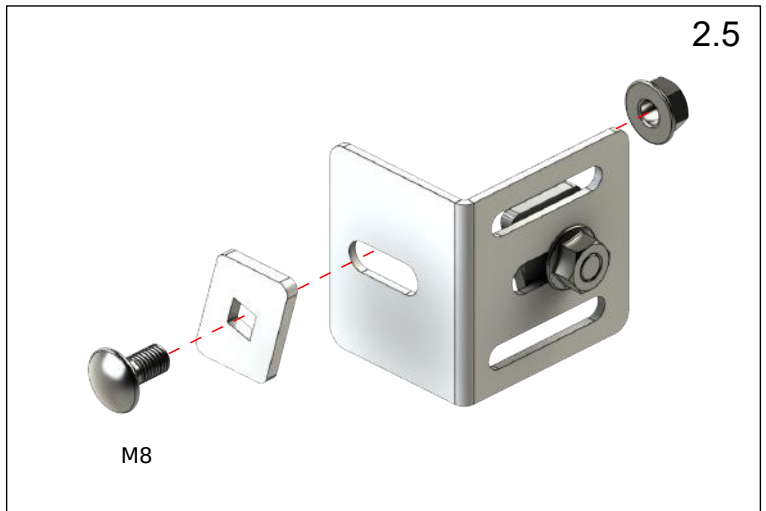

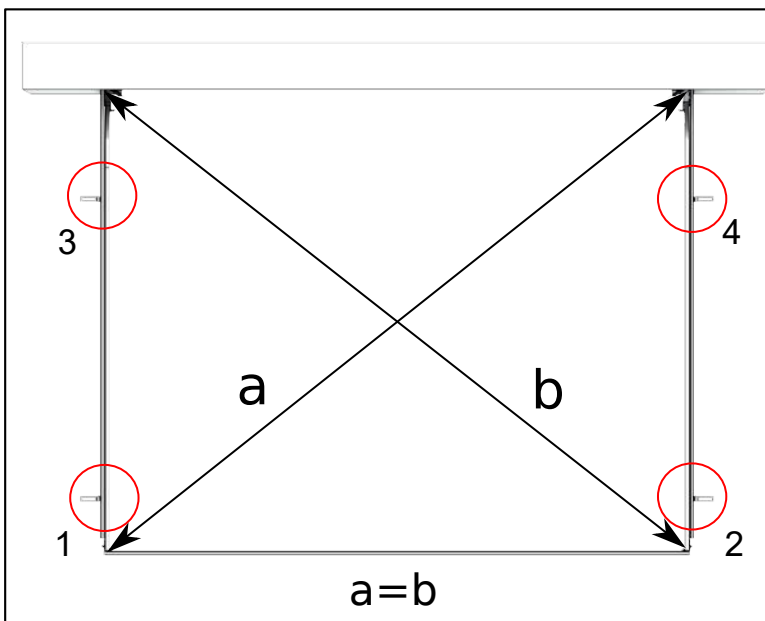
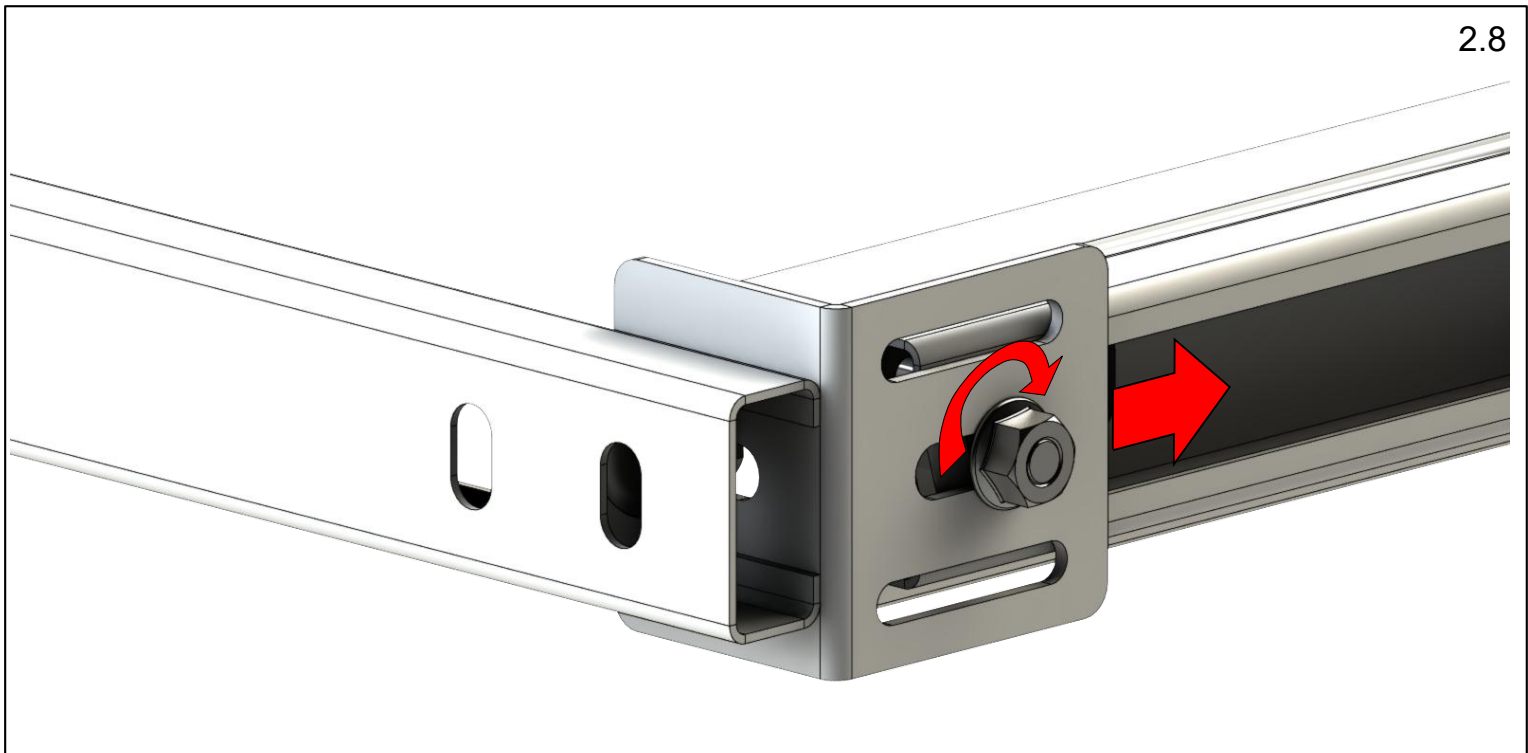
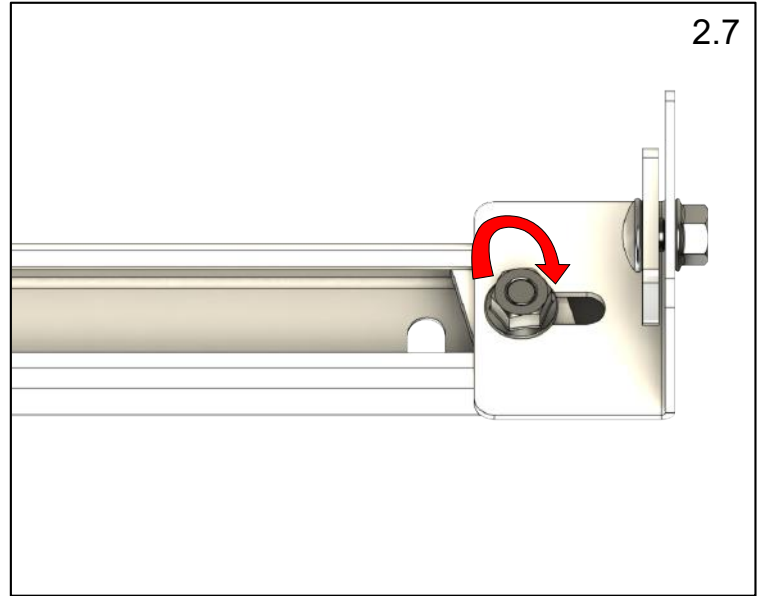
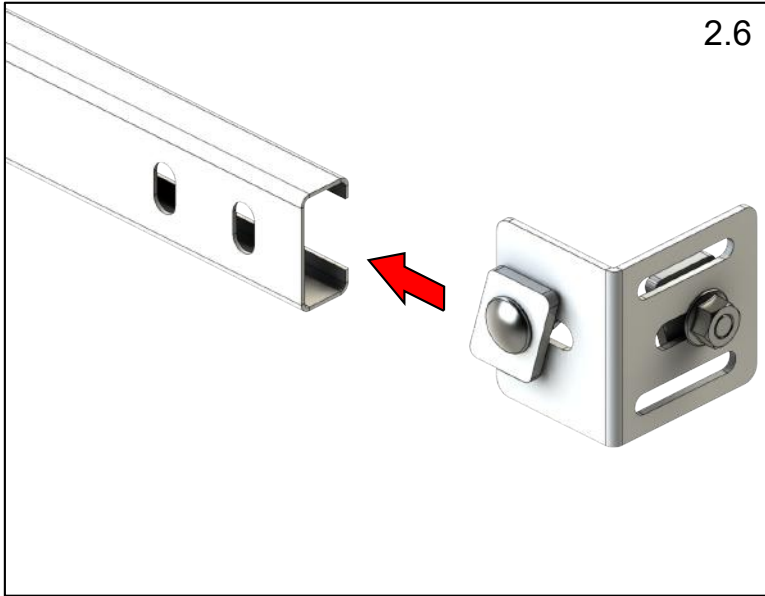

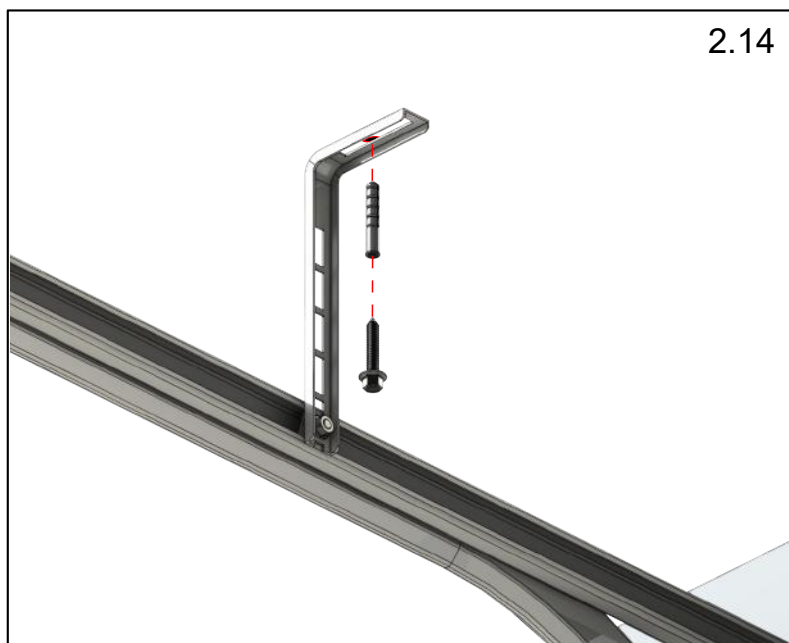
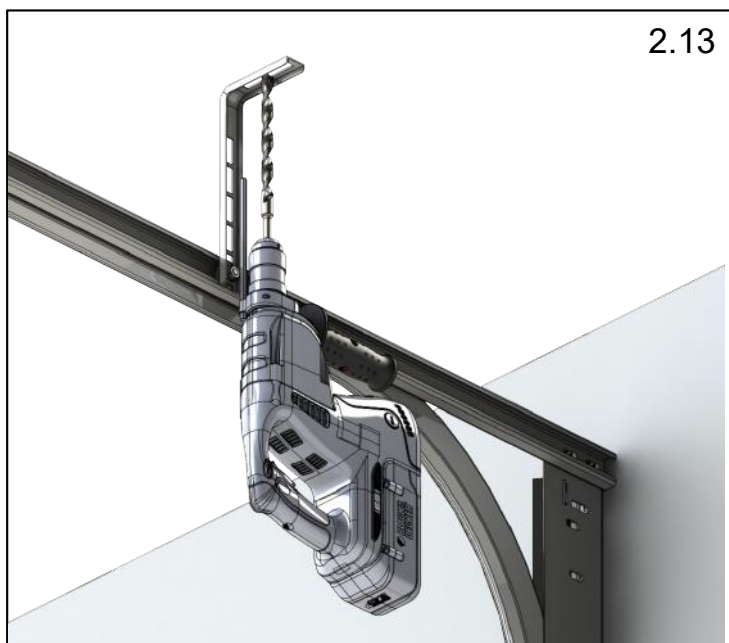
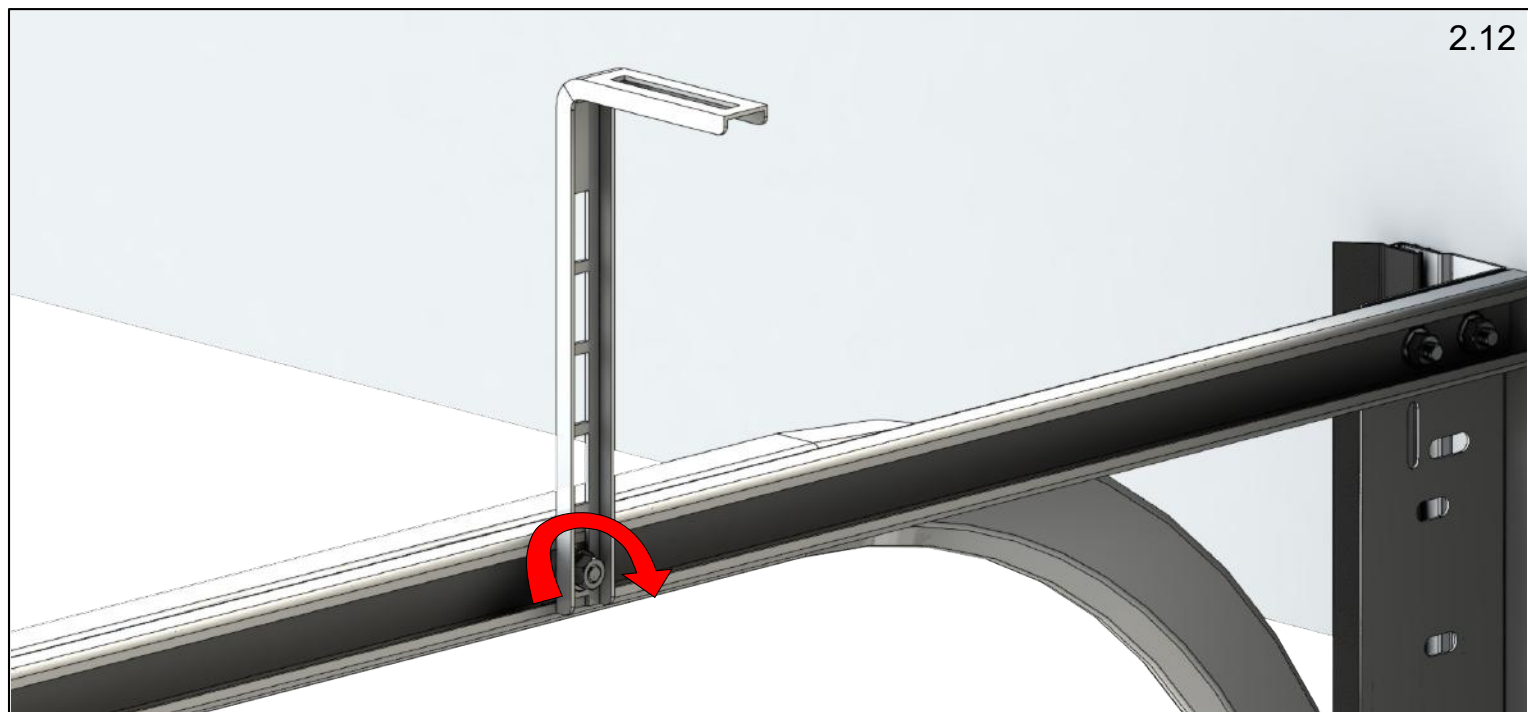
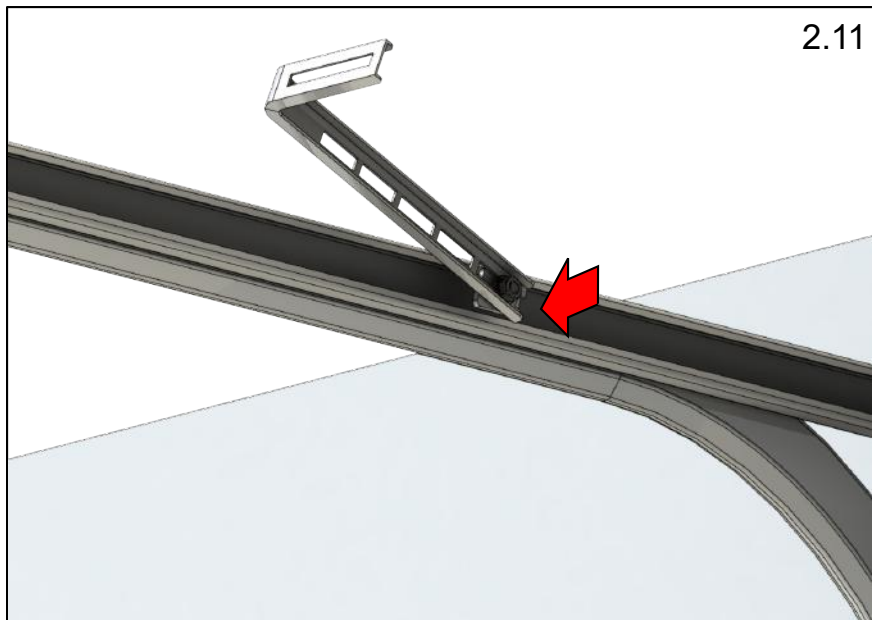
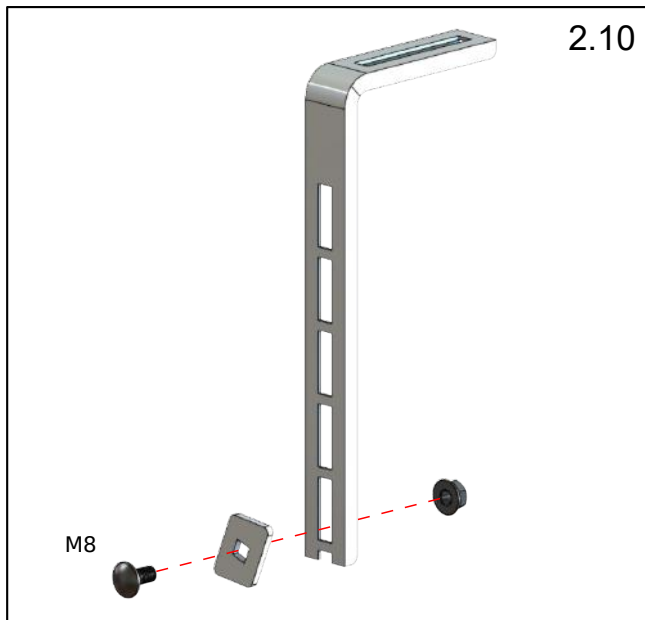

3.0

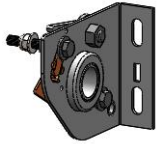
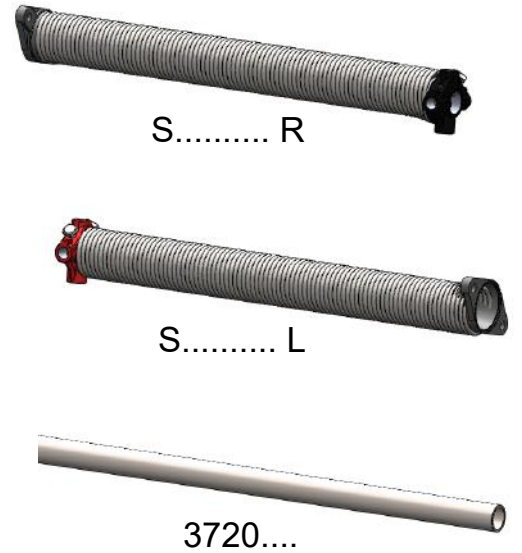

5255167-W L+R

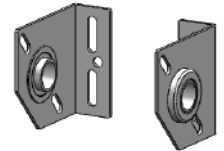
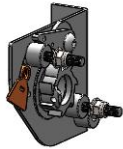

503067 L+R



40.. SL L+R

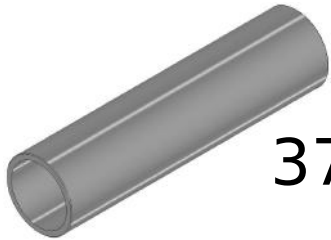

3720 < 100kg



3830 100-200kg

Coupler
W > 4000mm

OPTION

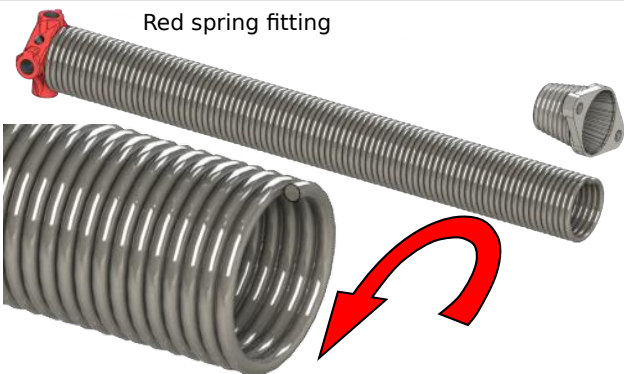
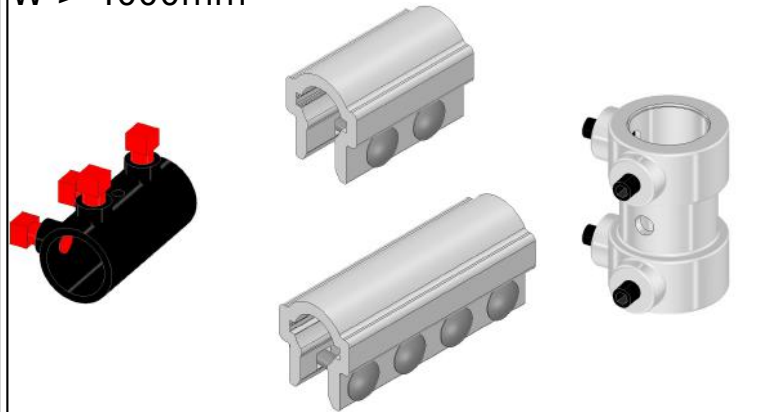

mount on the **left** side



mount on the **right** side

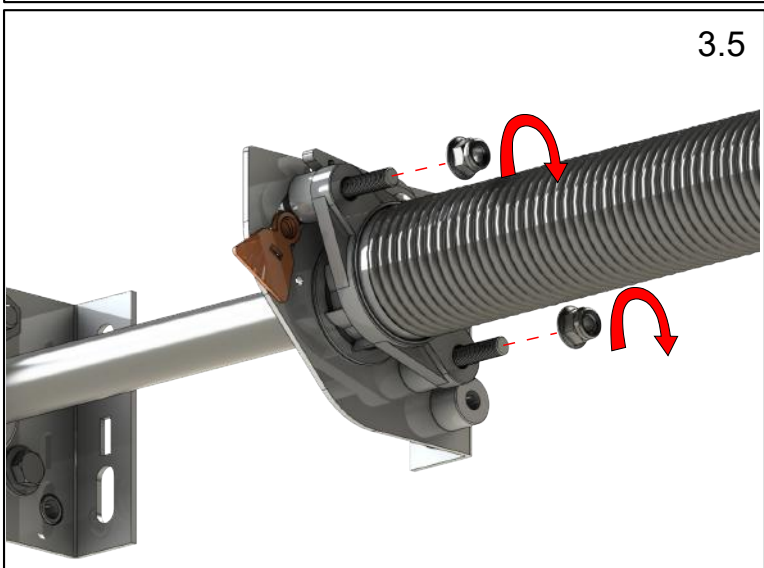
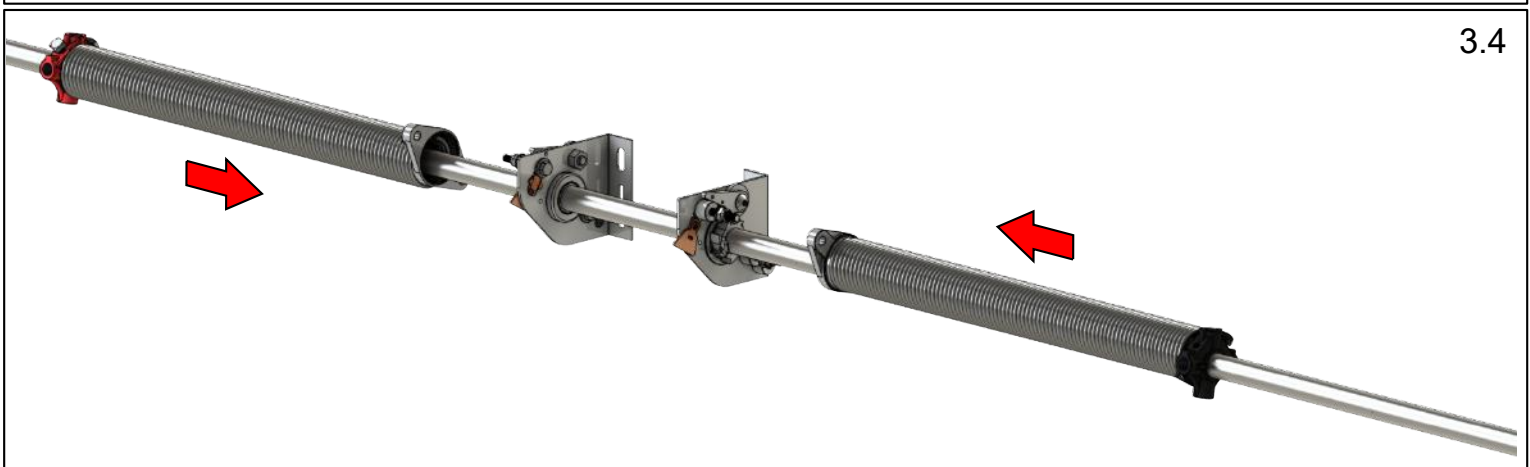
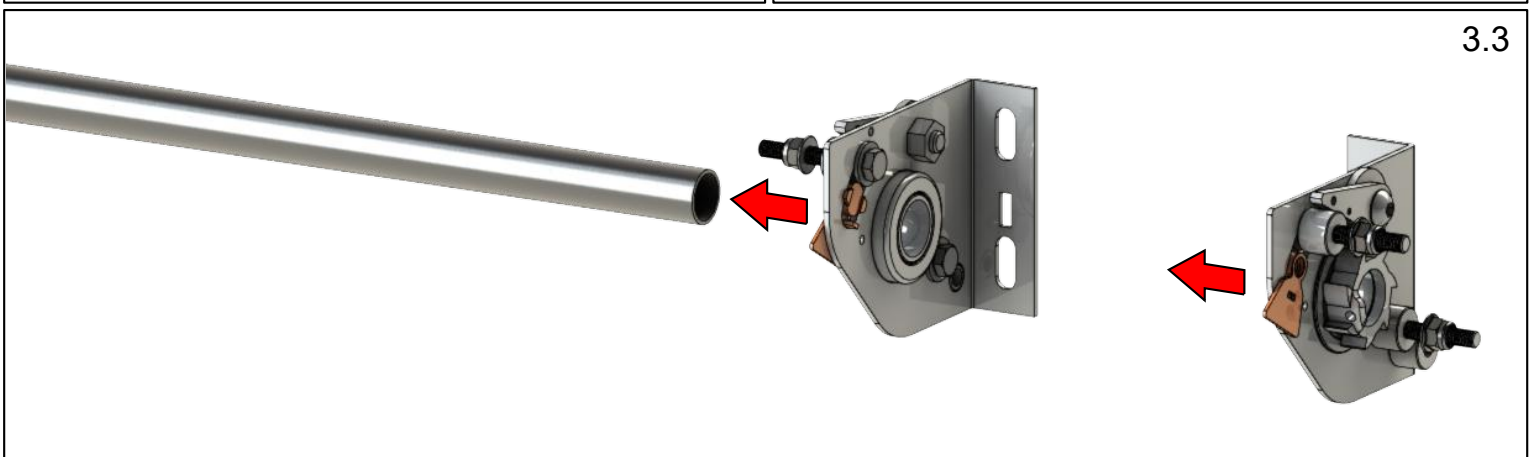
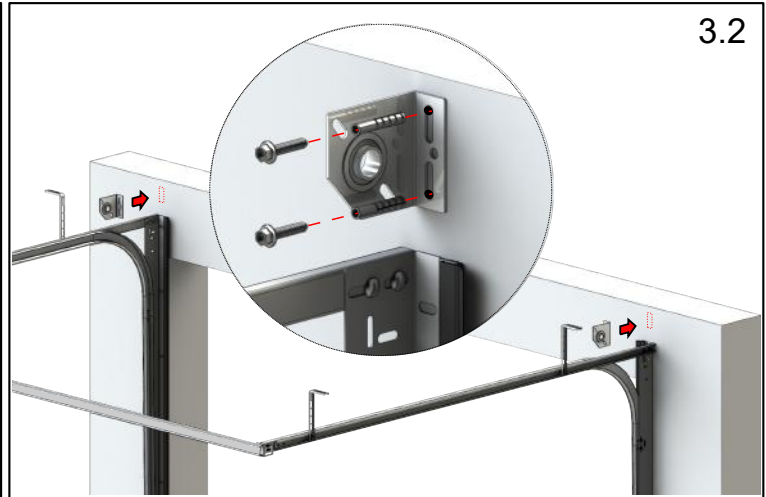
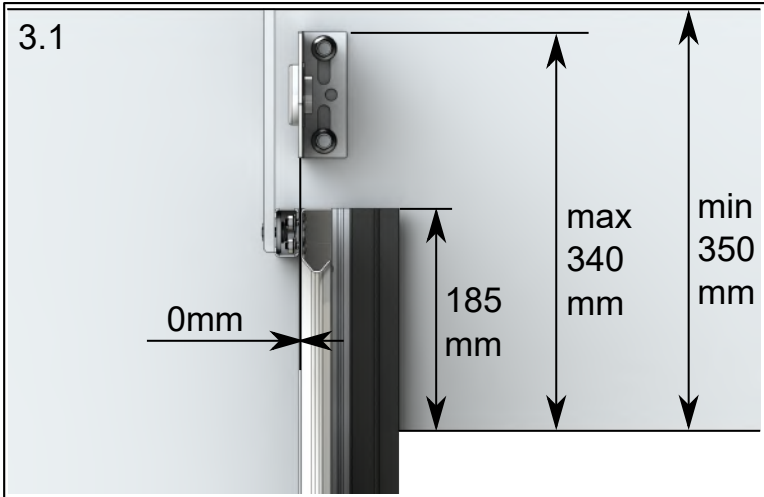

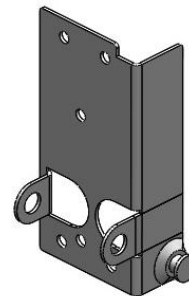
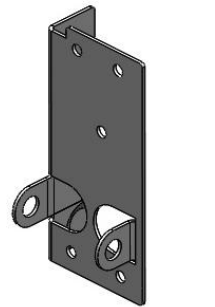
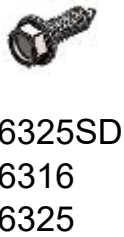
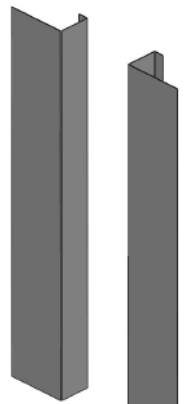
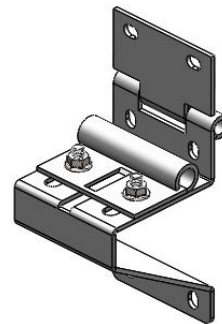
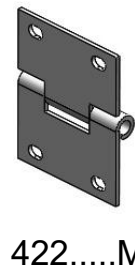
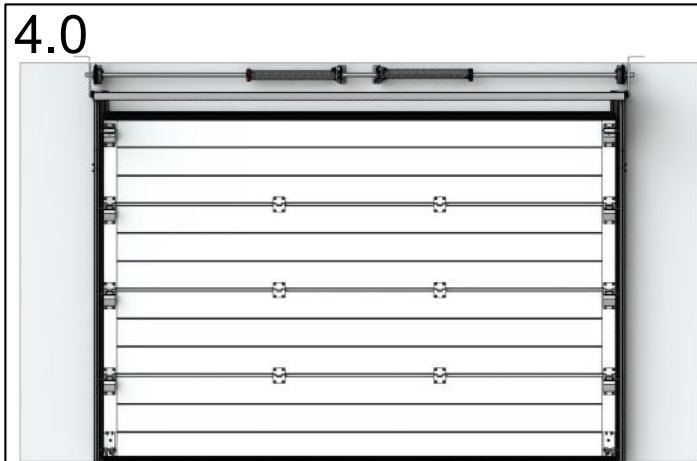
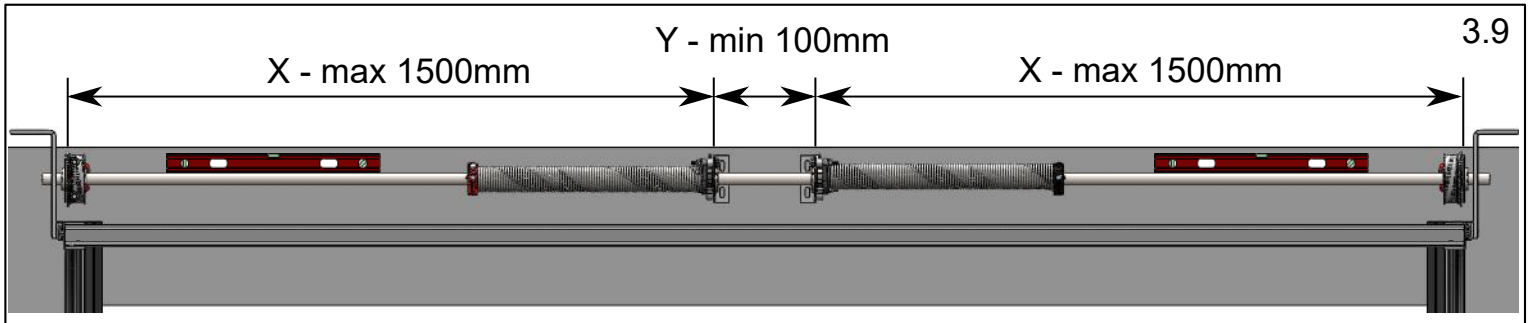
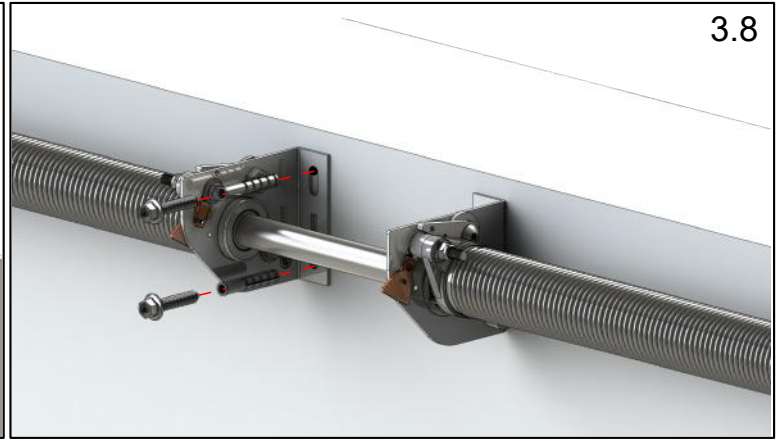
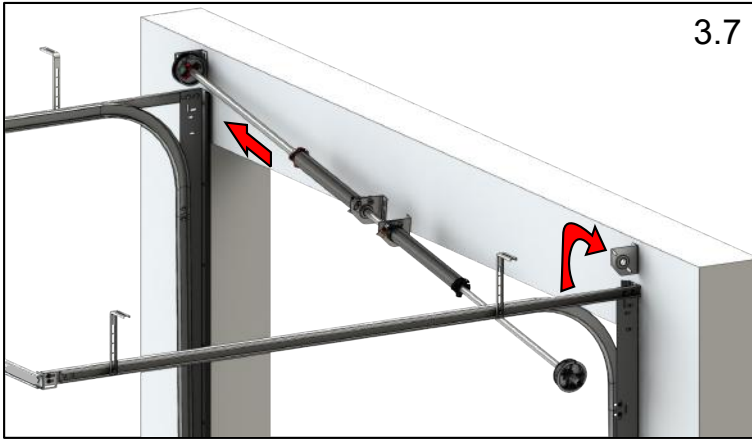

2002 x 2



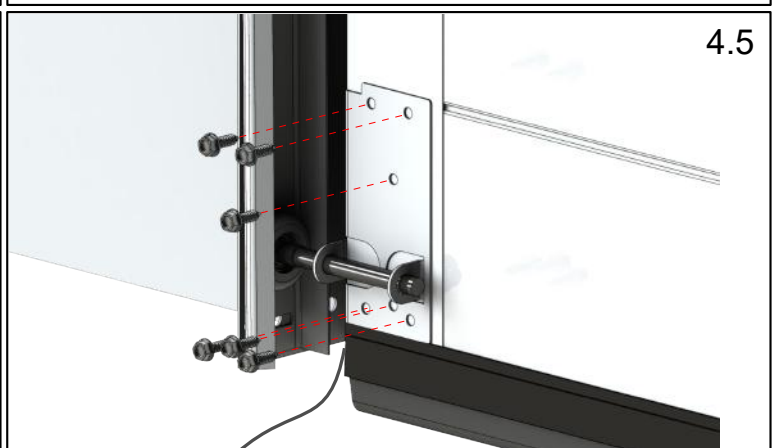
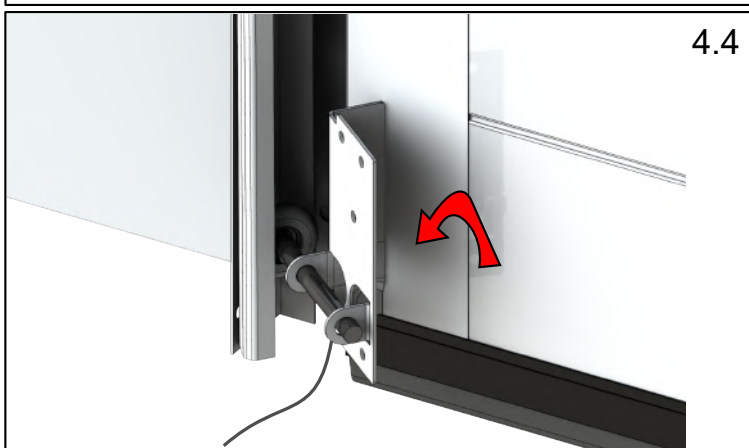
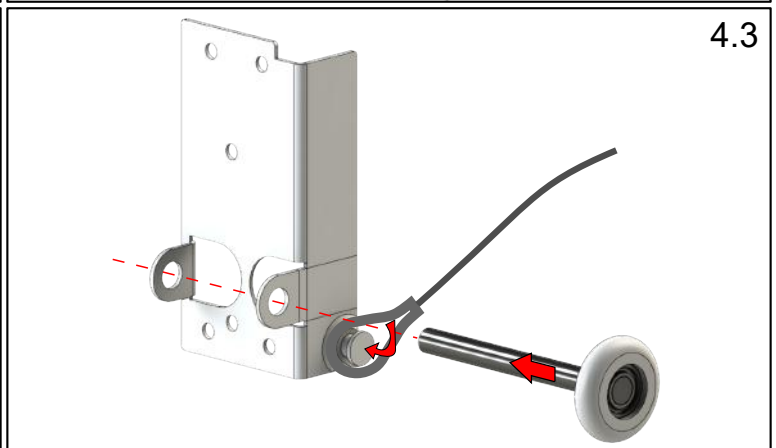
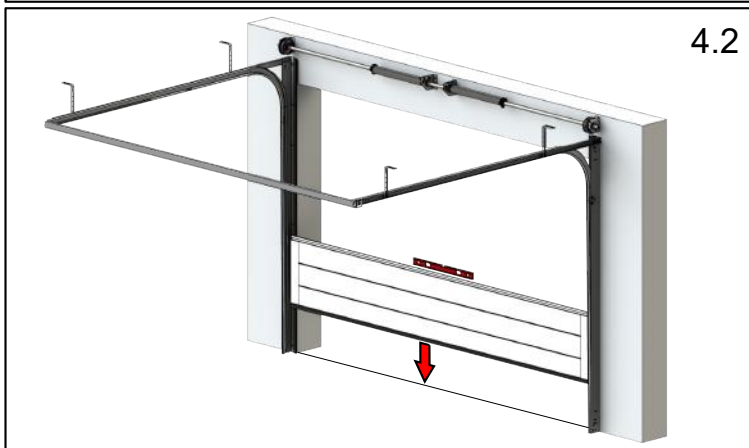
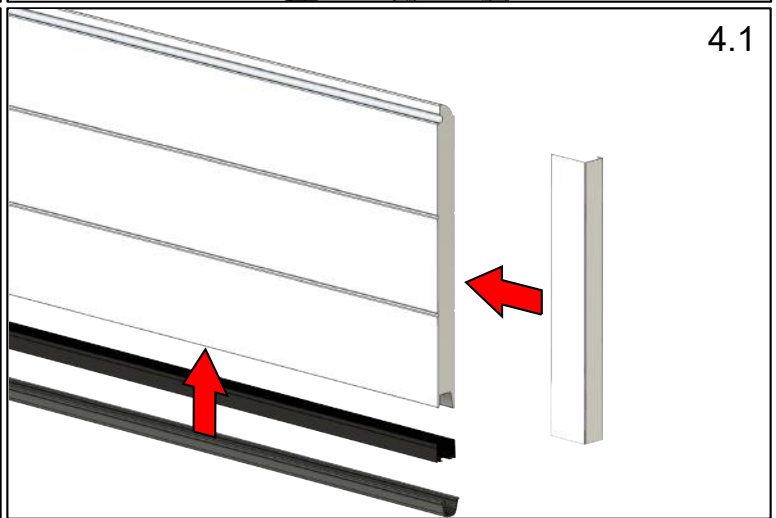
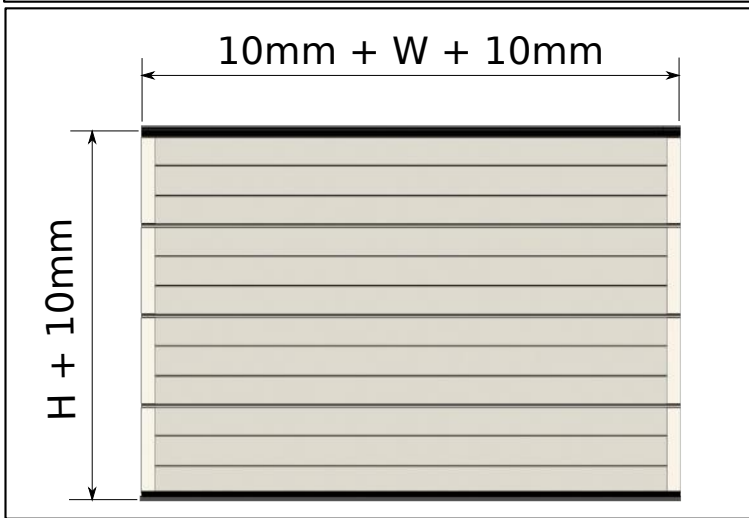
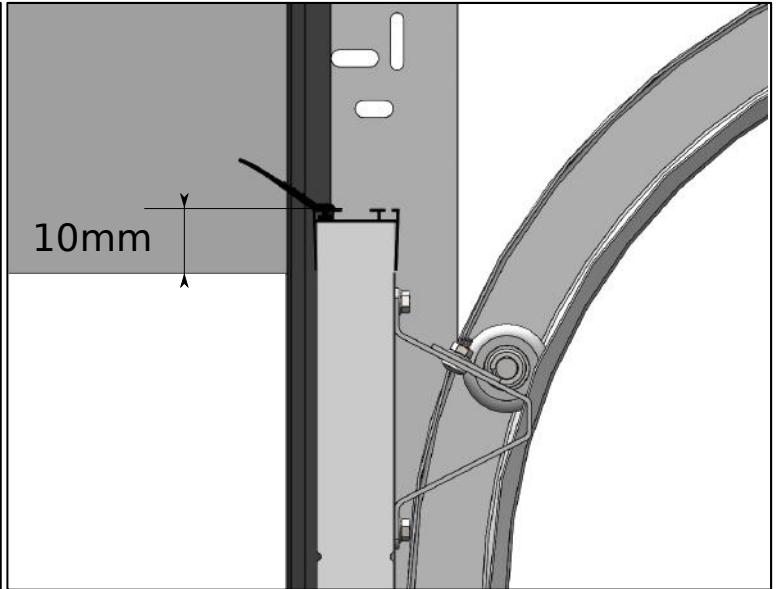
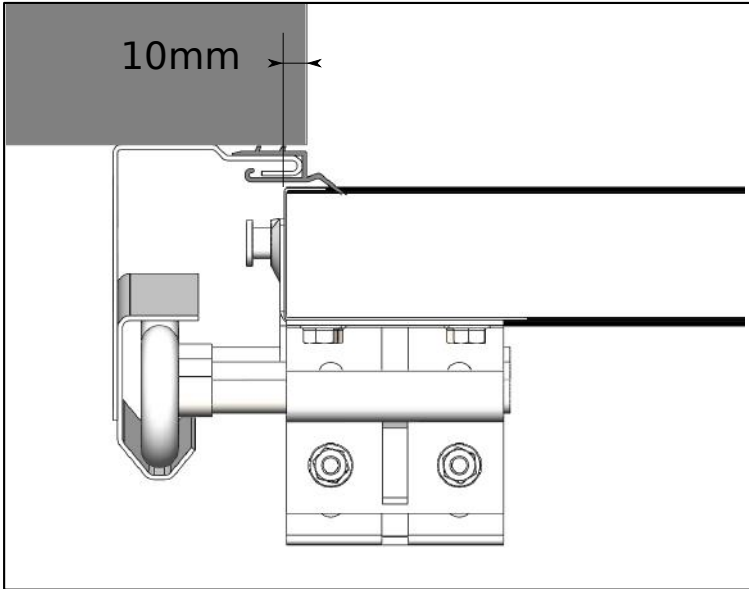



W	Number of middle hinges	4.8
0 - 2750mm	1	
2750 - 4000mm	2	
4000 - 5000mm	3	

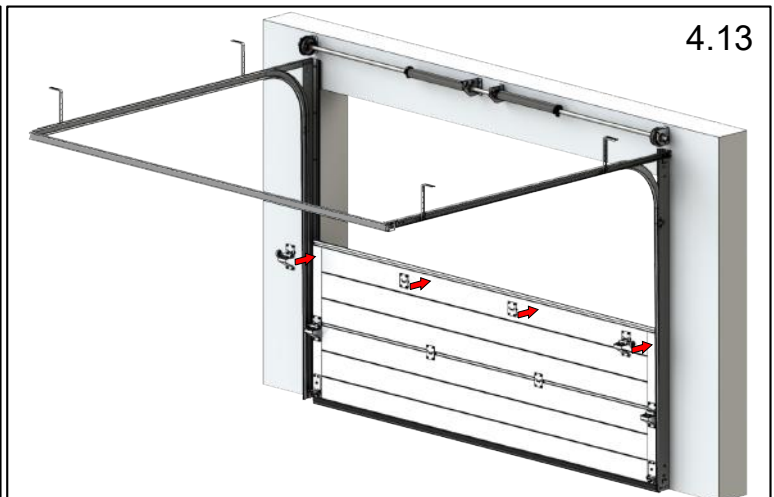
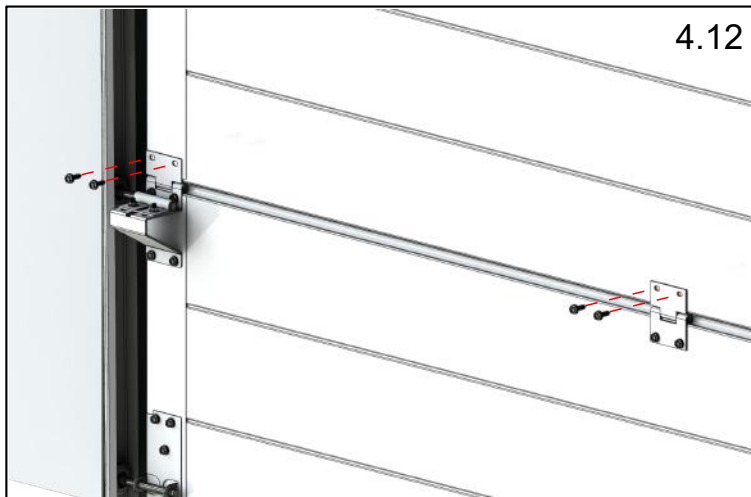
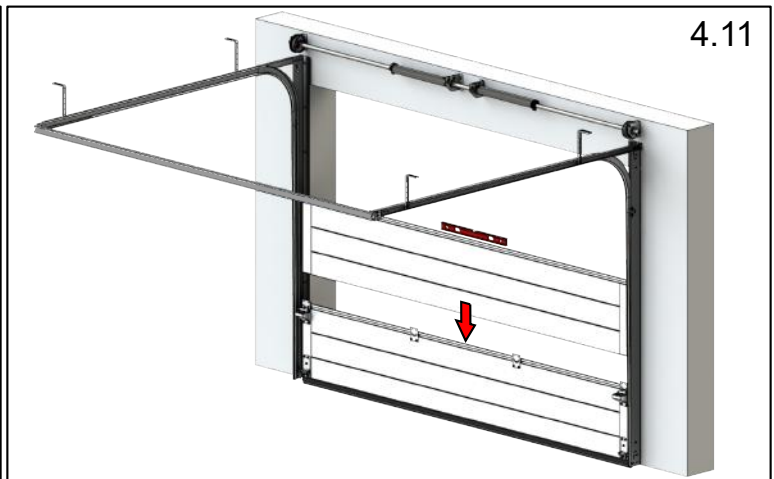
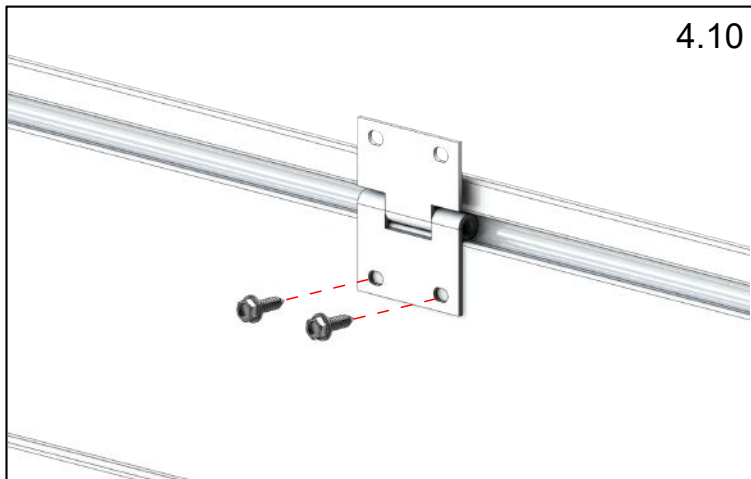
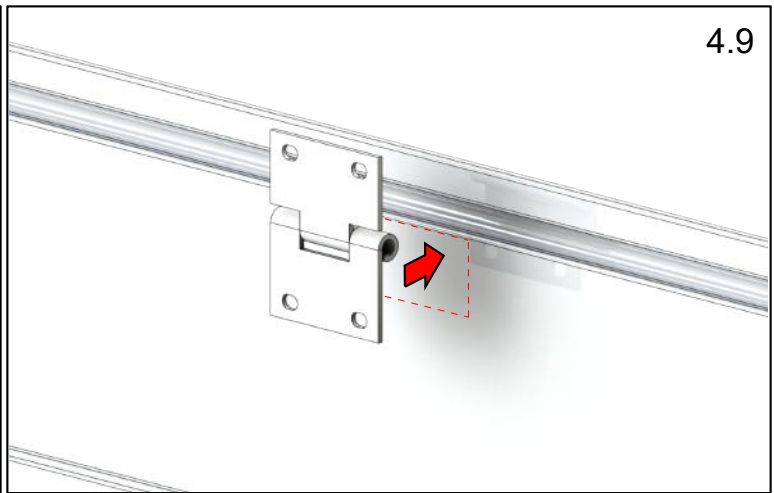

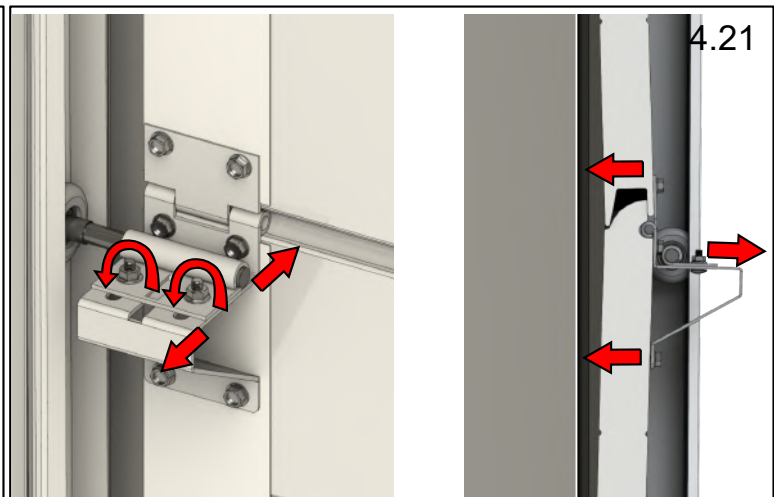
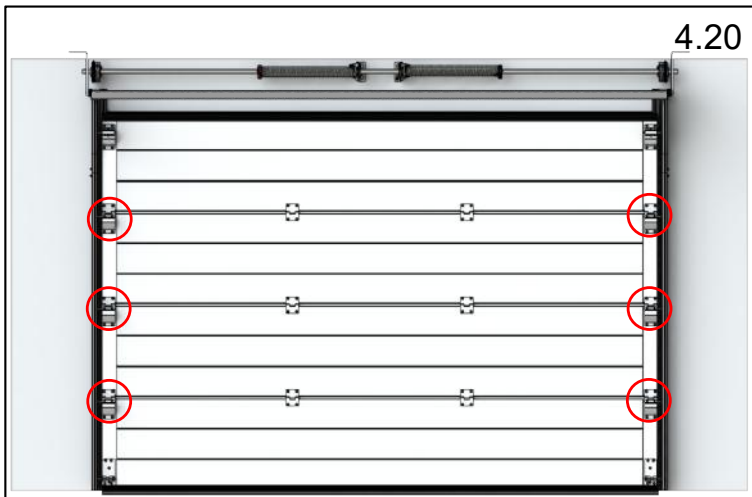
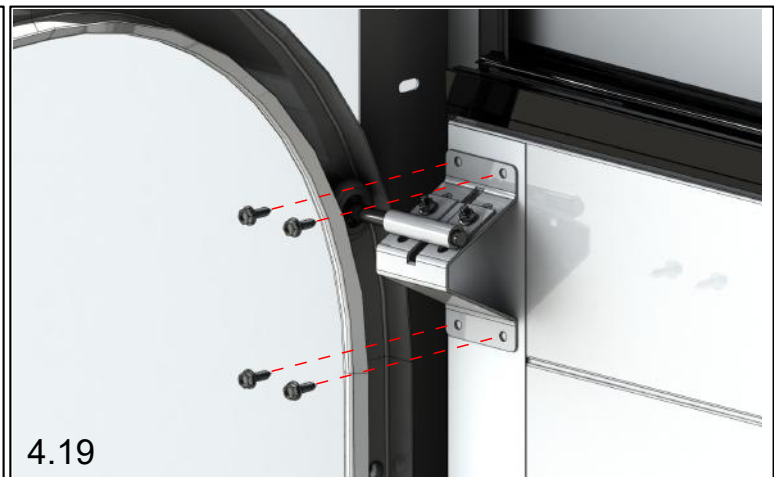
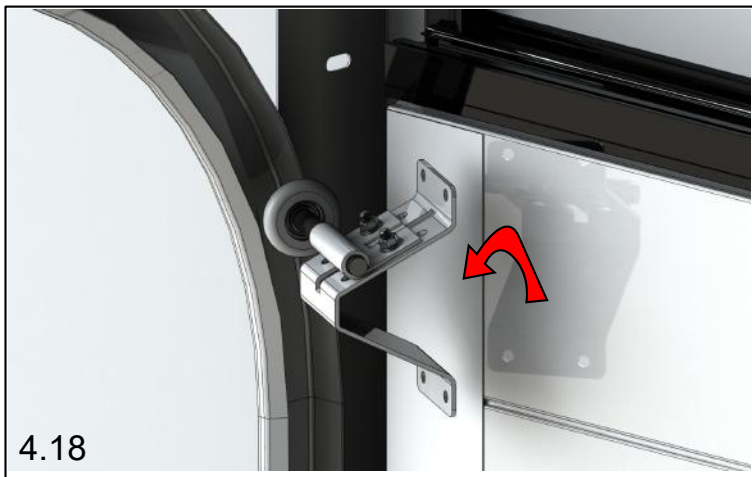
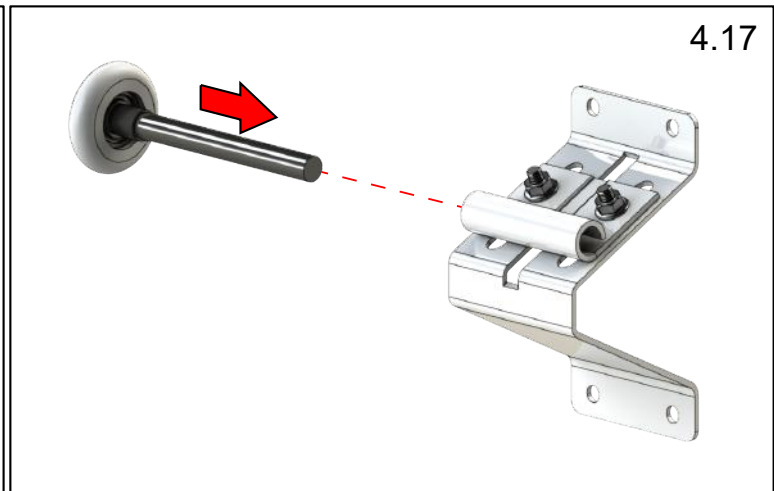
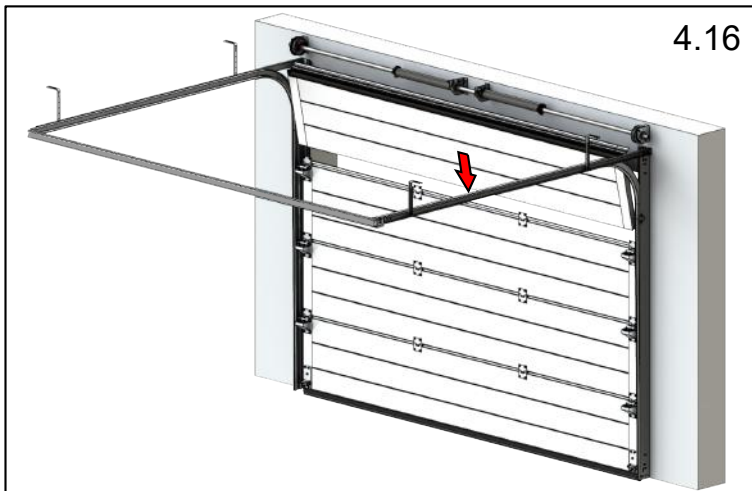
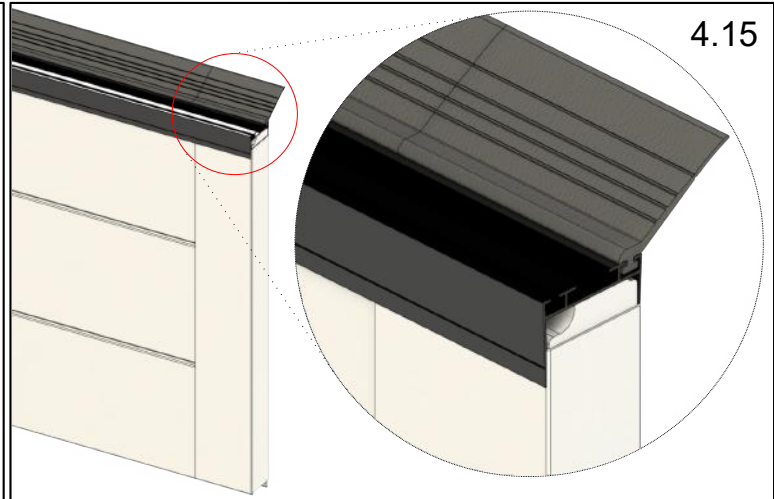
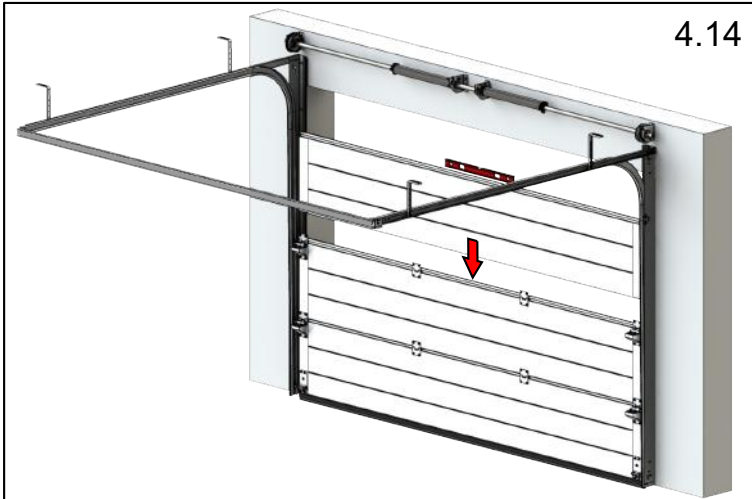

5.0

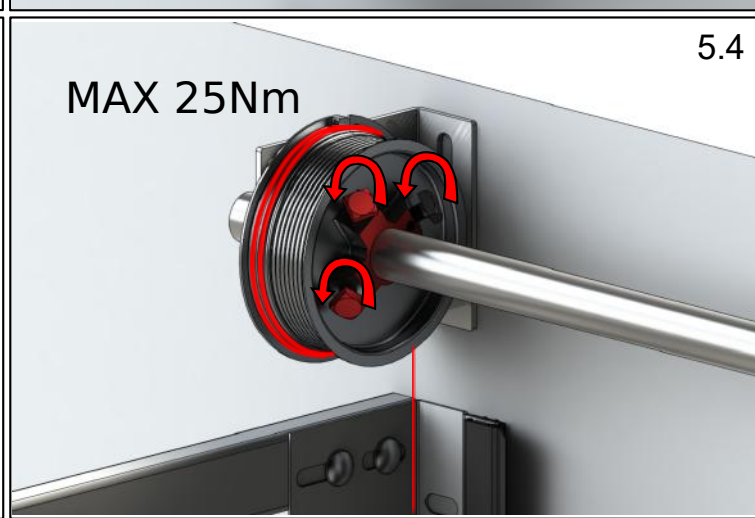
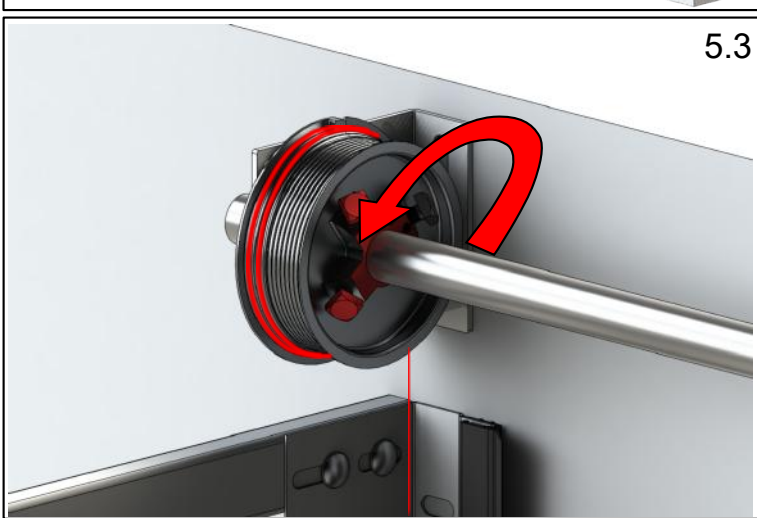
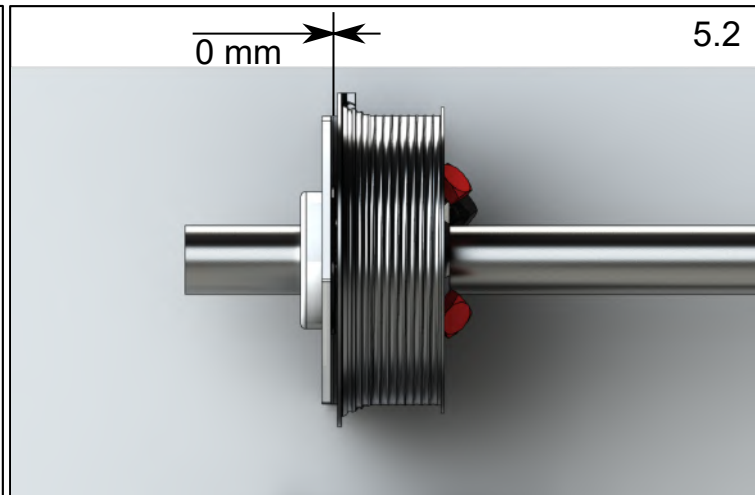
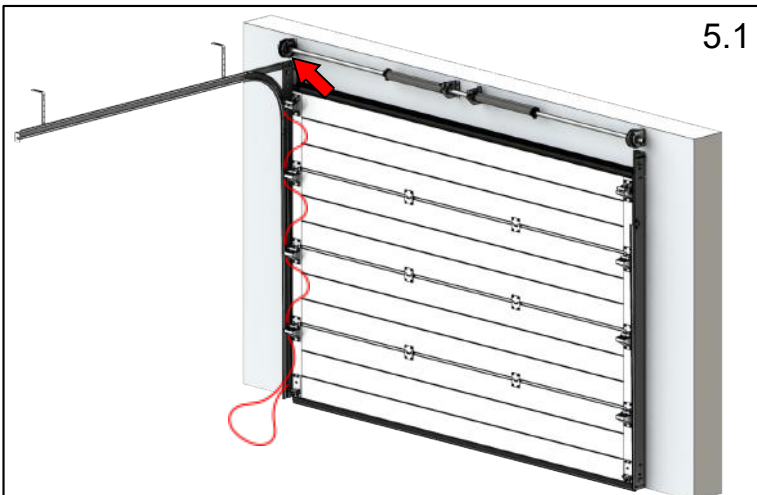
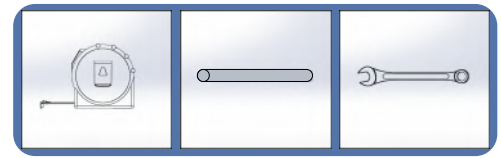
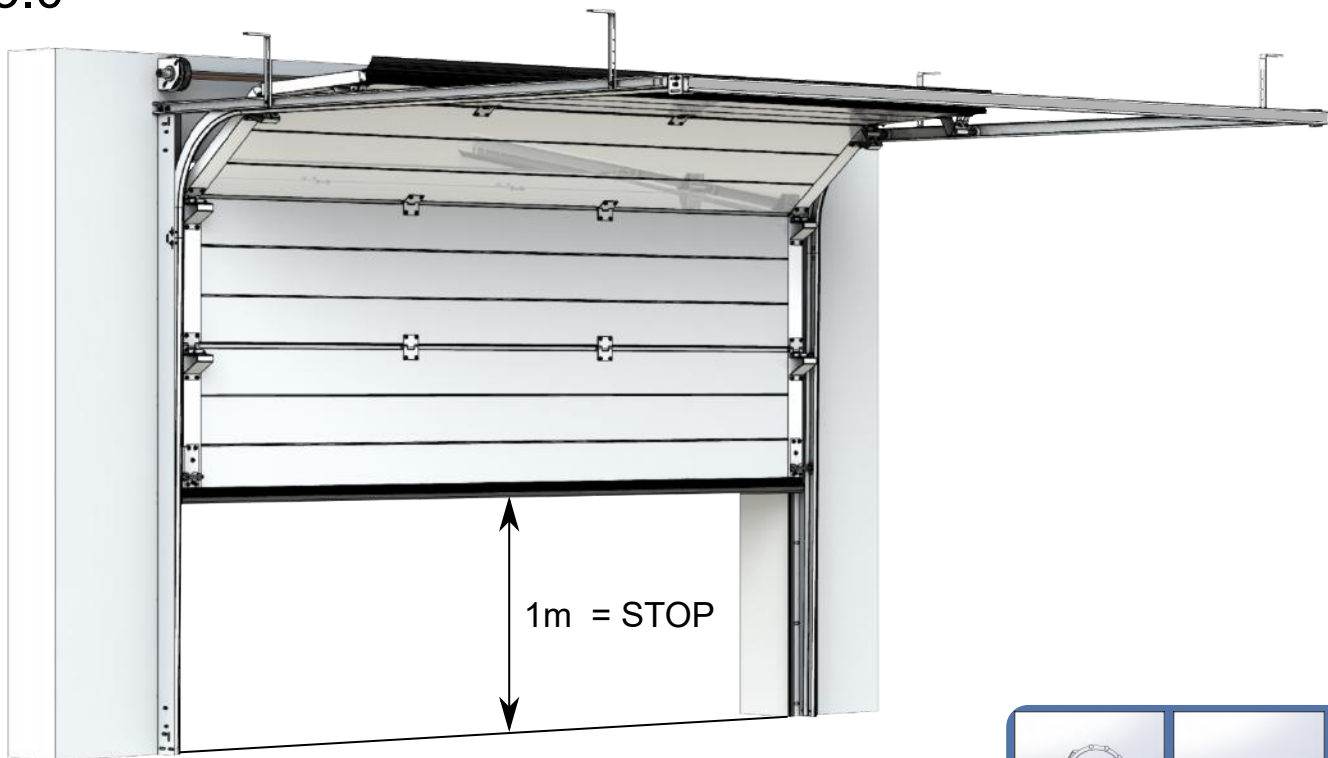

loose spring - markers in a line



torsion spring - markers show the number of turns



example 8 turns

Height	Number of spring turns		
	4panels	5panels	6panels
2000	7,1rotation	6,8rotation	----
2125	7,6rotation	7,3rotation	----
2250	8,0rotation	7,7rotation	----
2375	8,4rotation	8,7rotation	----
2500	8,5rotation	9,2rotation	----
2750	----	9,4rotation	----
3000	----	10,3rotation	----

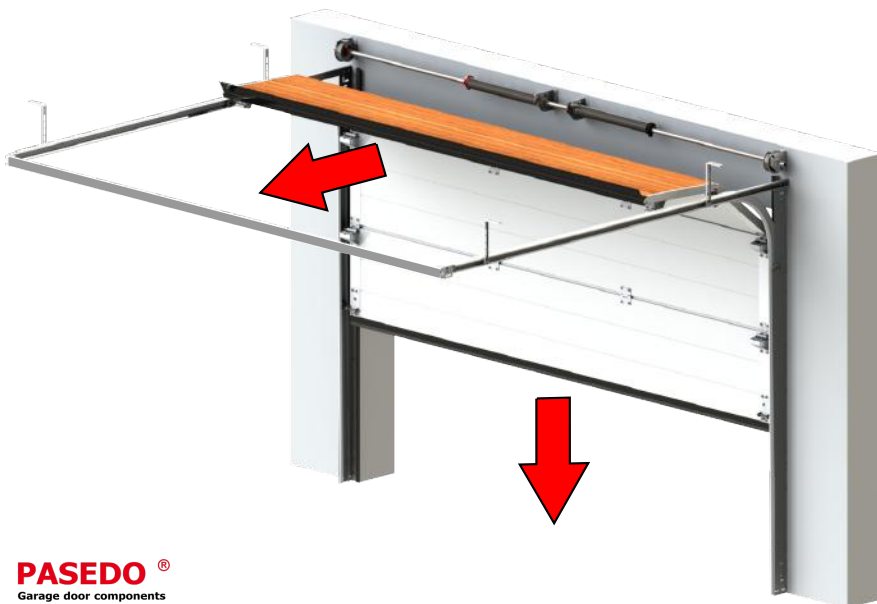
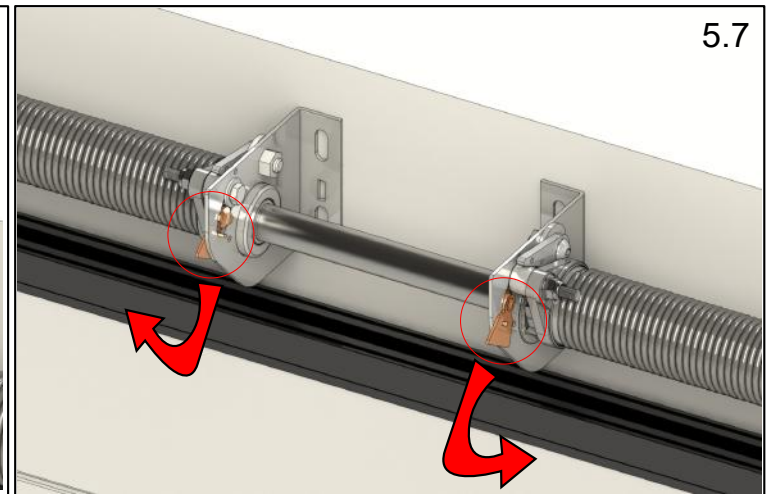
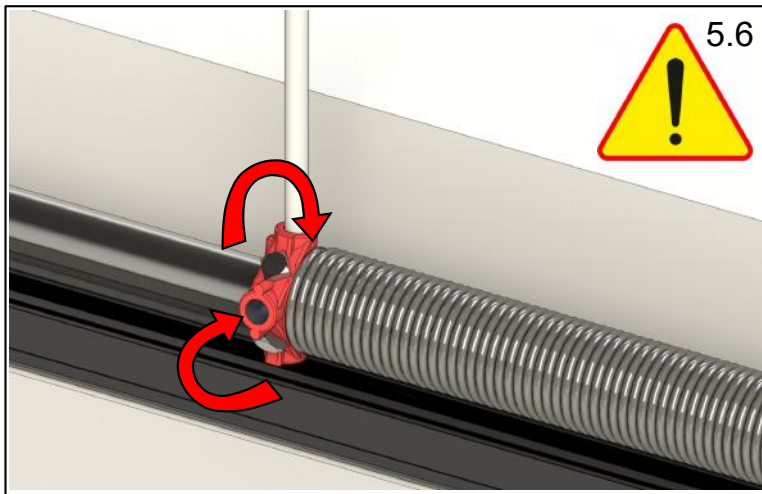
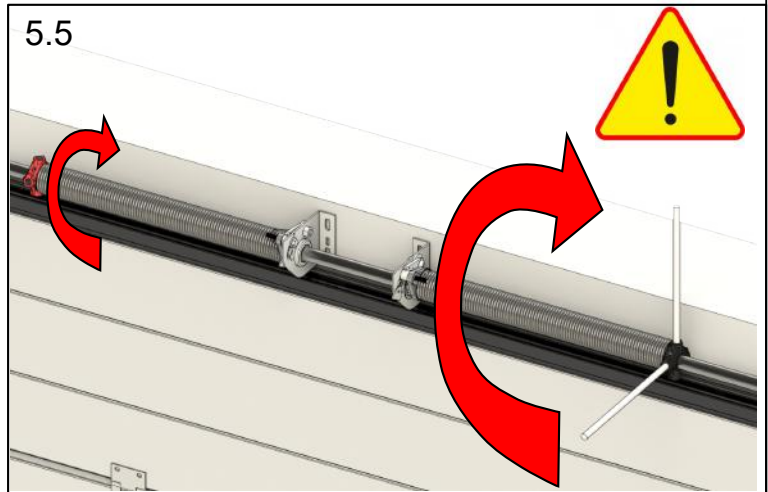

Nazwa lub znak identyfikacyjny i zarejestrowany adres producenta

Ostatnie dwie cyfry roku, w którym oznakowanie zostało umieszczone

EN 13241-1

Numer normy europejskiej

Opis wyrobu i zamierzone zastosowanie

Numer identyfikacyjny

Wodoszczelność [klasa techniczna]
 Odporność na obciążenie wiatrem [klasa techniczna]
 Opór cieplny [wartość]
 Przepuszczalność powietrza [klasa techniczna]

Informacje o wymaganych właściwościach wyrobu

CE

Oznakowanie zgodności CE symbolem CE Określonym w dyrektywie 93/68/EWG

89/106/WE; 98/37/WE; 89/336/WE

Powołanie odpowiednich dyrektyw